

Variable Chamber Round Balers

VB-VBP 2200 Series



www.KuhnNorthAmerica.com



Invest in Quality®

KUHN VARIABLE ROUND BALERS

CONSISTENT BALES IN ALL CONDITIONS

THE QUALITY YOU'RE LOOKING FOR

Field performance, bale quality and bale density are fundamental to the profitability of every operation. Every minute counts when weather conditions are uncertain. The unique innovations on KUHN balers make a real difference in field performance.

UNMATCHED RELIABILITY

KUHN offers the most efficient and versatile range of balers available on the market. KUHN balers are not only designed to produce top-quality bales, but are also built for unmatched reliability.

STAYING AHEAD WITH NEW INNOVATIONS

KUHN's Research & Development team is constantly improving their round balers to stay ahead of technology with innovations like: Progressive Density, Integral Rotor Technology and IntelliWrap.

VARIABLE CHAMBER ROUND BALERS

VB/VBP
in brief:

Models	Bale Diameter		Bale Size
	Min. & Max. (Inches)		
VB 2255	31 ½	63	4x5
VB 2260	31 ½	63	4x5
VB 2265	31 ½	63	4x5
VB 2285	31 ½	73	4x6
VB 2290	31 ½	73	4x6
VB 2295	31 ½	73	4x6
VBP 2265*	31 ½	63	4x5

*Small bale wrapping kit: 31 ½ – 60 inches

CONSISTENT, HIGH-QUALITY BALES

Consistent shaped bales bring more than just aesthetic appeal. A consistent filled bale represents quality in every form. Perfect firm round bales have less air in the bale, resulting in high quality feed!

BALE FORMATION

The bale chamber on the VB 2200 series consists of 3 bale chamber rollers and 5 belts. The belts and rollers in the bale chamber provide fast, consistent core formation. In this pre-chamber, moderate or soft-cores can be chosen to meet the needs of any feeding or bedding situation. The redesigned bale chamber is equipped with a new heavier top chamber roller with aggressive profile resulting in less material to the front of the baler. The VB 2200 series also has a reinforced tailgate bottom roller and top belt guide roller for added durability. A top forming roller in the front segment of the baler prevents crop build up and material on the machine.

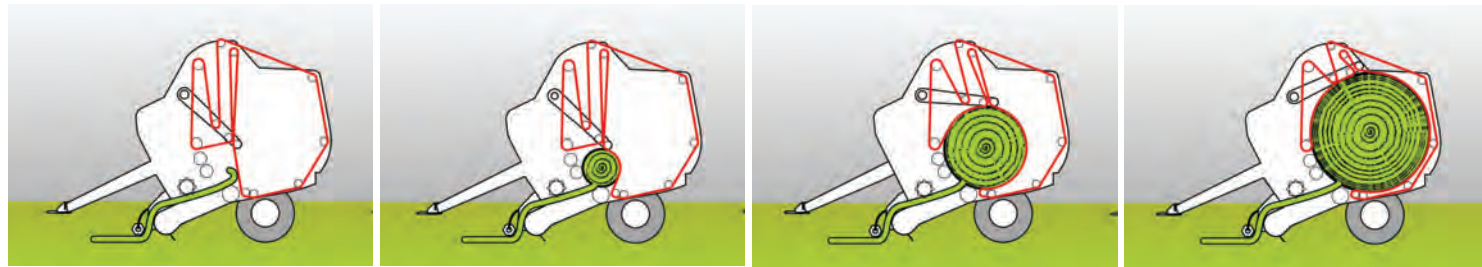

PROGRESSIVE DENSITY – PROVIDES DENSITY WHERE IT COUNTS

As the bale grows within the bale chamber, the belt tensioning arm is subjected to steadily increasing resistance from two hydraulic cylinders and a spring tensioner. As the diameter grows, the bale's density does too. The result is a very firm bale.

With a tougher outer layer, straw bales will be more tolerant to weather conditions, while hay bales will maintain their shape for improved stacking and easier handling.

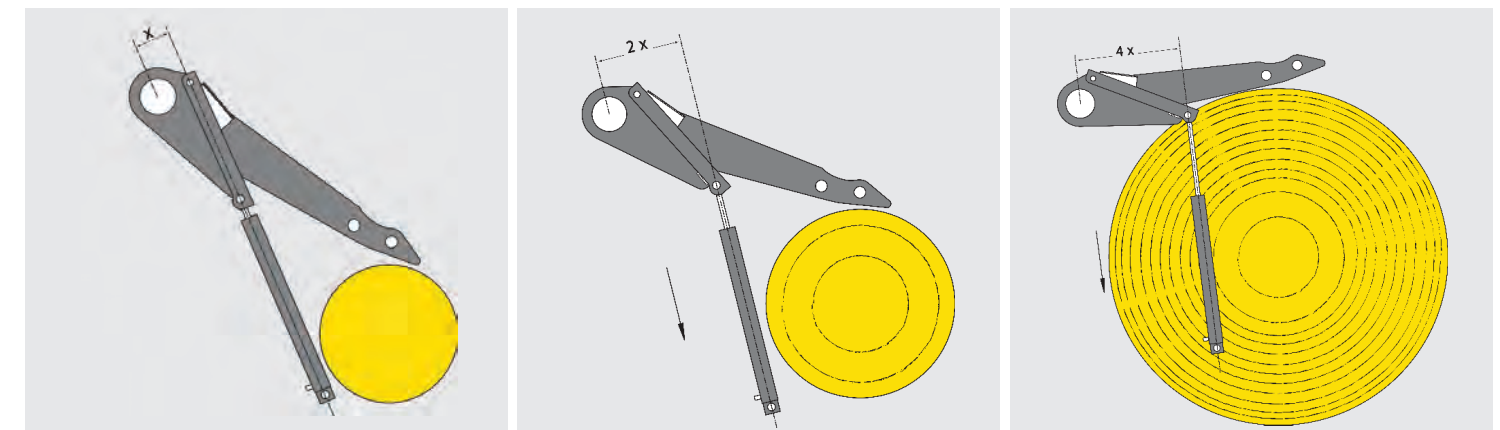

VERSATILITY TO MEET YOUR OPERATION'S NEEDS

To better meet your operation's specific needs, there are four different intake options available on the VB 2200 round balers. Select from an OptiFlow open throat intake design, an OptiFeed non-cutting rotor, or a 14- or 23-knife OptiCut integral rotor.

OPTIMAL CROP PICKUP

All VB 2200 models feature a wide pickup with standard crop roller. The pickup is designed to maximize the full capacity of the machine. With a working width of 83 or 91 inches, the machine is capable of working in all windrows and will not let you down, even in the toughest conditions. Straight pickup tines help release the crop and reduce crop wrapping. The pickup roller compresses the crop against the pickup tines reducing friction, thus reducing leaf loss and increasing baler efficiency by evening out the windrow.

The new OptiFlow open throat models are equipped with an unrestricted 83" wide pickup. The driven bottom and top roller combination brings maximum thrust to the crop flow for full capacity.

The 91" rotor model pickup features standard pendulum frame and optional pivoting pickup wheels to allow the pickup to adapt to changing field conditions.

Uniquely shaped crop guides, on 91" pickups, result in more aggressive and efficient pickup by exposing more of the tine when needed and by pulling the crop away from the tines as it approaches the intake.

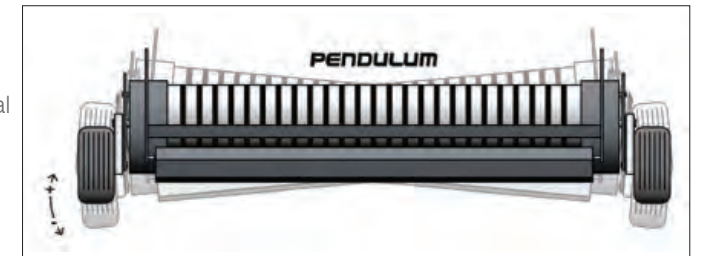

Pivoting pickup available on 91" rotor models only



NON-CUTTING INTAKE SYSTEMS

When cutting the crop is not what you're looking to do, the OptiFlow and OptiFeed intake systems ensure a controlled and consistent crop flow to the bale chamber. (availability dependent on VB model):

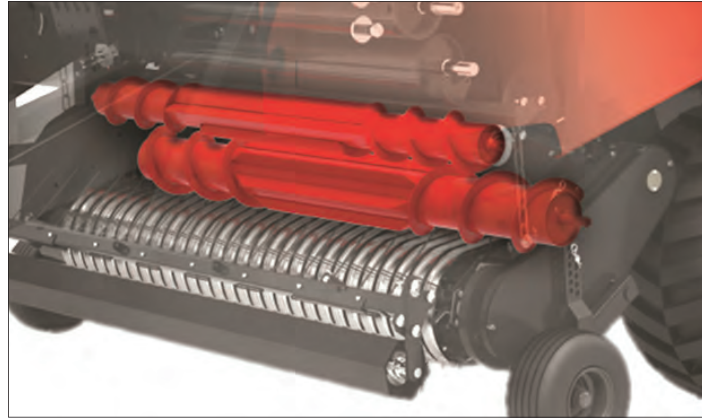

OPTIFLOW – OPEN THROAT

The OptiFlow open throat intake has an unrestricted intake unit for maximum capacity in all crop conditions. In heavier conditions, like big wide straw or silage windrows, the top roller is acting like a pre compactor which is powered by the primary driveline of the baler. There are no stuffer fingers which can disturb the flow and therefore limit the intake capacity. This generates a huge input potential and prevents plugging of the unit resulting in a high output and minimum downtime.

VB 2255/2285/2260/2290 models only

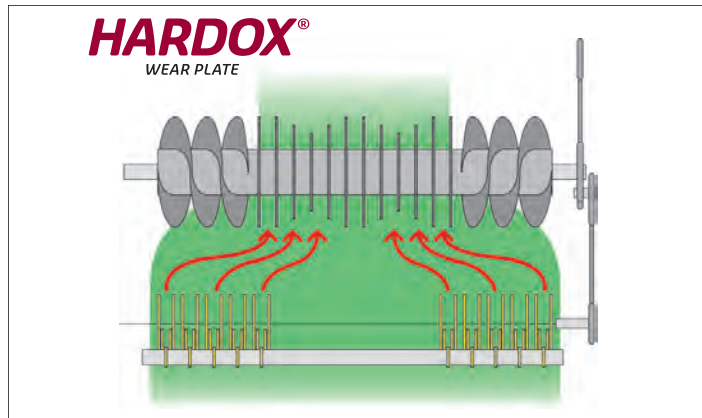

INTEGRAL ROTOR - CROP FLOW CONTROL

VB balers without OptiFlow are equipped with the patented Integral Rotor Technology. With the exception of the VB 2255-2285, all Integral Rotor units are provided with tines made out of Hardox wear plates. Hardox combines extreme hardness and toughness with minimum wear of rotor tines. The simple, maintenance free, short-distance intake system ensures even feeding regardless of variations in crop conditions. The short distance between rotor and pickup yields an outstanding crop flow. This force-fed intake makes higher forward speeds possible for outstanding productivity and reduced crop damage.



OPTIFEED ROTOR

The OptiFeed rotor with single feeding tines and integrated augers, provide a consistent flow of crop into the bale chamber. This rotor design helps even out incoming windrows for consistent bales every time.

VB 2255/2285/2260/2290 models only

CUTTING INTAKE SYSTEMS

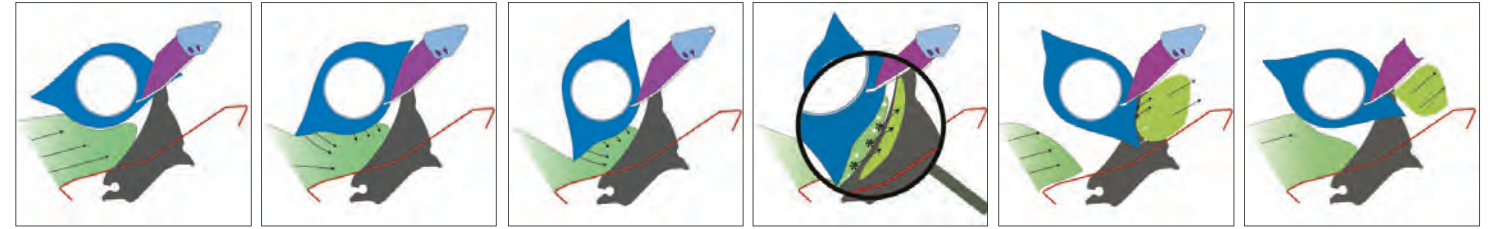

The Opticut (OC) cutting systems are designed for unlimited intake capacity and excellent cutting quality.

There are two different types of KUHN OC cutting systems on the VB 2200 series. (availability dependent on VB model): Due to the unique bi-lobe rotor and cam-shaped lobe, the silage is guided and drawn to the knives in an early stage which improves flow and cutting performance and also helps prevent unwanted plugging. As a result of the redesigned intake unit the power requirement of the round balers is decreased.



OPTICUT 14

The Integral Rotor with the 14-knife OptiCut system is designed to even out the windrow and force-feed the crop into the baler for maximum throughput. The 14-knife OptiCut cutting system provides a theoretical cutting length of 2 3/4". Each single knife is spring protected against damage from foreign objects.

VB 2260/2290 & VBP 2265 models only



OPTICUT 23

The Integral Rotor with the 23-knife OptiCut system from KUHN has the benefits of intensive cutting and mechanical protection. The 23-knife OptiCut system provides a theoretical cutting length of 1 3/4". Each single knife is spring protected against damage from foreign objects. With group selection the operator can choose to have 0, 7, 11, 12, or 23 knives in operation.

VB 2265/2295 & VBP 2265 models only



GROUP SELECTION

Mechanical group selection is available on VB 2265-2295 & VBP models. Easy knife changing will provide you with true driver comfort.



ROTOR DISENGAGEMENT AND DROP FLOOR TECHNOLOGY

When dropping of the floor is not sufficient, the rotor drive can manually be disengaged from the bale chamber drive, enabling the binding and discharge of the bale from the chamber. The rotor disengagement and drop floor technology ensure a quick clearance in case of an obstruction.



In case of a rotor obstruction, the floor and knives can be lowered hydraulically from the tractor cab. After the obstruction is cleared, they can easily be brought back into work position.

FIRM BALE SHAPE

STRETCH TYPE NET WRAPPING SYSTEM



NON-STOP BALING

The net and twine cycle is crucial during baling. Less time required for binding means a higher output. On the KUHN balers the binding is placed at the front of the machine, resulting in a perfect view on the binding process from the tractor seat. To optimize this process, main adjustments can be done via the monitor.

NET WRAP SYSTEM

The net wrap system with active stretch technology assures a firm bale shape with constant high net tension throughout the entire binding cycle. The net is fed into the front of the bale chamber to secure an even and direct start. A second net roll storage guarantees sufficient net supply for a long working day. Changing the net roll can easily be done standing safely on the ground next to the machine.

KUHN's innovative design allows constant tension to the net during the binding process. The net wrap system runs at 90% of the bale's rotational speed, to be able to stretch the net instead of braking. This provides a constant net tension in all crop and weather conditions. After leaving the bale chamber the bale will not expand and therefore holds its density.



SIMPLE & PRODUCTIVE



AT-10
black & white display

The new VB 2255 and 2285 models are the right round balers for the job, providing the capability and performance you expect without any extras to weigh you down. We took our former AutoPlus models and made them even better with a reinforced pickup, new top forming roll, reinforced end gate roller and our all-new OptiFlow open throat intake to complement our popular OptiFeed non-cutting rotor intake. The end result is a round baler that will handle a variety of crops, moistures and crop conditions with ease.

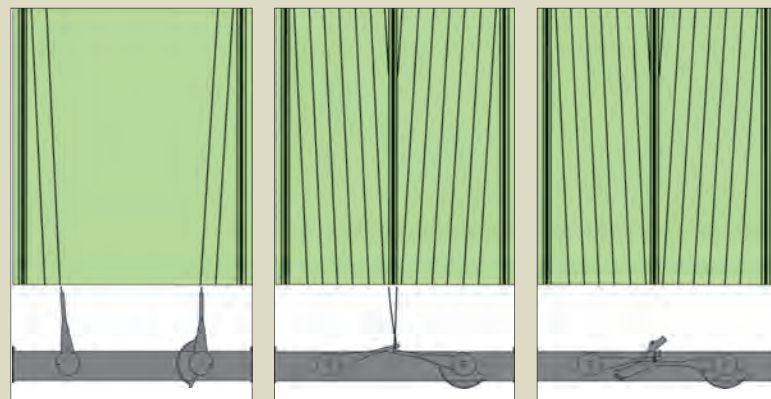

TWINE SYSTEM

Use of the double twine arm system reduces the tying cycle time to a minimum. The twine system can be easily programmed with a preselected choice or you can customize your own settings with the baler monitor from the tractor seat.

During the tying process, both twines start at the bale center and overlap themselves, then move to the edges of the bale. Then, the twines gradually move back to the center. At the final stage, the twines overlap to ensure that they are tied and there are no loose ends.

The VB and VBP can be equipped with a twine only or twine and net combination.

Twin tubes feed twine simultaneously

Center twines overlapped

No loose ends at edge of bale



Low-profile, 4-tine bar pickup



Heavy-duty chains and hardened sprockets

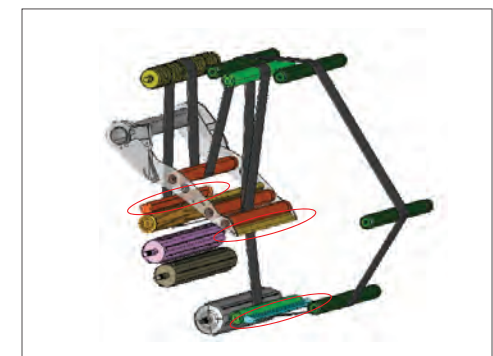

Silage ready scrapers



VARIABLE CHAMBER ROUND BALERS VB 2265 / 2295 / VBP 2265

EXTREME DENSITY

The KUHN VB 2265 and 2295 elite class round balers are designed to work in the toughest conditions throughout the world and are ideal for custom operators who need extra density in straw. Built for high-volume hay production, these models feature the most heavy-duty components to keep you producing rock-hard bale after bale, day after day.

HIGHER DENSITY

The VB 2265-2295 balers can run on a higher baling pressure with up to 10% increase of bale weight in dry crops.

EXTREME SILAGE CAPABILITIES

The bale chamber is provided with a second belt drive to keep the belt turning in the heavy silage conditions. In addition, all new belt guide rollers in the bale chamber carry heavier bearings and improved seals to meet the highest demands.

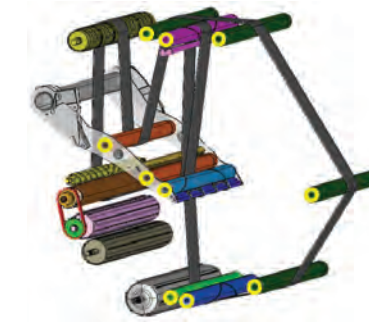

Heavy bearings and seals



VARIABLE CHAMBER ROUND BALERS VB 2260 / 2290

PREMIUM PERFORMANCE

Hard work calls for a hardworking round baler. The VB 2260 and 2290 models are premium class round balers with full ISOBUS control and a wide range of intake options including the OptiFlow open throat, OptiFeed non-cutting rotor and the OptiCut 14 cutting rotor. These machines work well handling anything from heavy silage to dry cornstalks with the added convenience of ISOBUS monitors and upgraded silage features.



ISOBUS full color monitors



Low-profile, 5-tine bar pickup



Heavy-duty chains and hardened sprockets

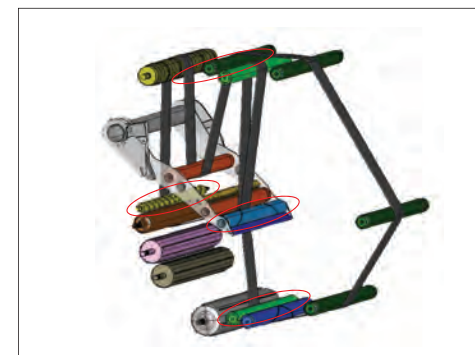

Increased silage capabilities with profiled cleaning rollers

DURABILITY

All VB 2265-2295 models have increased overall driveline quality. The new integration of u-joints in the main line, heavy-duty drive chains and belt track rollers contribute to an improved lifetime of the machine. The second belt drive roller helps guarantee a secure belt drive in all crop conditions. In addition, all VB 2265/2295/VBP 2265 models are equipped as standard with Beka Max continuous chain oiling system. The sturdy and wide oil brushes on the chains ensure perfect lubrication.

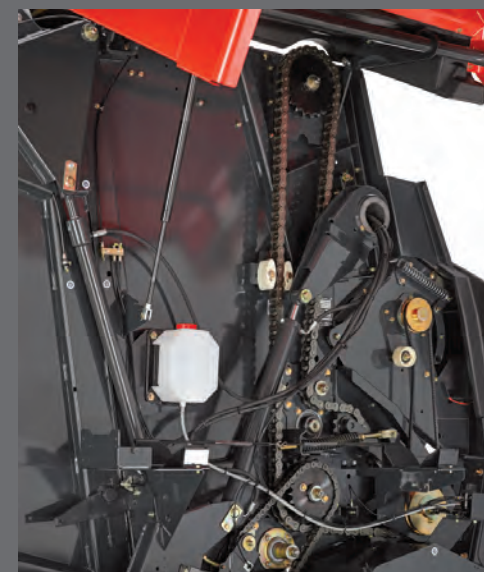

Extremely heavy-duty drive chains



U-joints in the main driveline



Separate knife/Drop Floor controlled from the tractor seat

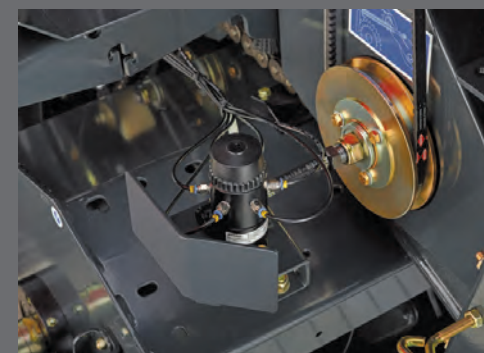

Beka Max continuous chain oiling system



Sturdy and wide oil brushes

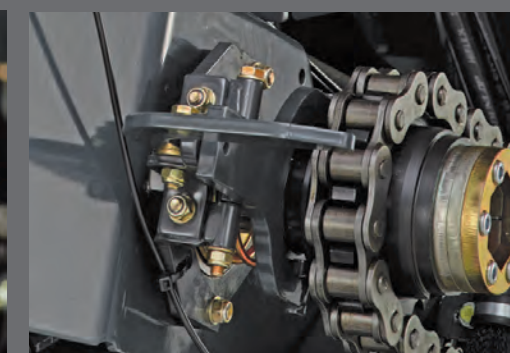

High density hydraulic system setup



VARIABLE CHAMBER ROUND BALERS VBP 2265

BALING AND WRAPPING: A ONE-MAN OPERATION

Two technologies from KUHN are combined into one machine to create the VBP 2265 Variable BalePack. This baler-wraper combination begins with a standard VB 2265 variable chamber baler with an OptiCut integral rotor and merges it with an innovative wrapper system. This purpose-built machine is simple to use and capable of working in all crop conditions, even on hilly ground.

Fast and reliable bale transfer, combined with a high-speed, twin-satellite wrapping unit equipped with IntelliWrap, gives the KUHN VBP BalePack the capacity to reach an output of up to 60 bales per hour.



PATENTED, SIMPLE PRE-STRETCHER

The pre-stretcher holds two 30" rolls of film and maintains a 70% stretch evenly throughout the roll. Conical ends maintain optimum film width and reduce tearing. Aluminum construction avoids buildup of tack from the film. The design and location makes it very easy to change film rolls compared to competitive models.

RAPID, RELIABLE BALE TRANSFER

RAPID AND RELIABLE

To minimize idle time and maximize output, rapid bale transfer is required. Since all bales are not made in perfect field conditions, the VBP is designed to ensure rapid bale transfer, even when working in sloping fields.

1. The first loading fork (in red) collects the bale as it leaves the bale chamber. The wrapping table is tilted forward; ready to receive the bale.
ADVANTAGE: There is no possibility for the bale to roll over the end of the wrapping table when facing up a slope.
2. The second loading fork (in blue) transfers the bale onto the wrapping table. The tailgate shuts automatically, with the second loading fork still in the raised position.
ADVANTAGE: This saves time and also prevents any chance for the bale to roll forward onto the tailgate when facing downhill.
3. The wrapping table returns to its horizontal position and the second loading fork is lowered. The bale sits low on the table supported by four wide belts and four lateral guide rollers.
ADVANTAGE: Regardless of the bale shape, the table offers strong support and allows perfect wrapping.
4. The IntelliWrap wrapping system with close mounted pre-stretchers rapidly wraps the bale, either in conventional or (optional) 3D mode.
ADVANTAGE: Vertically mounted pre-stretch units ensure that no hay gets between the layers of film during the wrapping process. This results in effective sealing between film layers and the highest possible haylage quality.
5. The low mounted table allows the wrapped bale to be gently discharged while driving, either automatically or manually.
ADVANTAGE: When working on sloping ground, the wrapped bale can be discharged while the net or twine is being applied on the following bale, saving time and increasing output potential.



WRAPPING

IntelliWrap, The Intelligent Wrapping Technology

KUHN has been a pioneer in wrapping and baling technology. The latest result of this visionary approach is a revolutionary wrapping technique called IntelliWrap. This technology uses computer-controlled electronics and hydraulics to monitor the wrapping process and continuously control the film overlap, allowing complete flexibility.

For the best conservation and fermentation of your valuable crop, wrapping the bale is crucial in this process. Depending on personal preferences, crop conditions and the storage period 5 layers of film may be enough, while in other circumstances 7 layers of film are preferred. Using IntelliWrap adjustments are simple—from your tractor seat you can easily adjust the number of film layers on the monitor. Just select 4,5,6,7,8 (no other wrapper manufacturers offer selection of 5 or 7 layers) or more layers of film and confirm. When selecting 5 layers, a minimum of 5 layers of film are applied to each and every portion of the bale.



Selection of 5 film layers

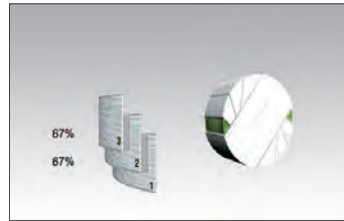

The bale is covered with 3 layers and 67% overlap

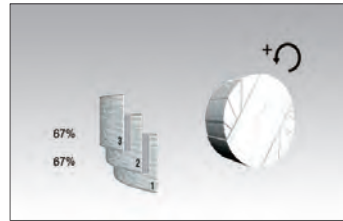

Increasing of the bale rotation speed

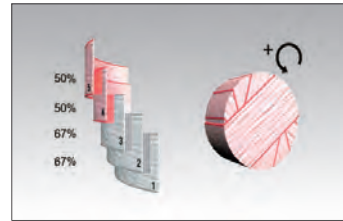

Final 2 layers with 50% overlap



The scissor film cutters ensure a clean, consistent cut



CUSTOMIZED TO FIT YOUR OPERATION

ELECTRONICS

ISOBUS

ISOBUS compatible tractors with a VT terminal will not require an additional monitor for the baler. Alternatively, the VT 50 or CCI 200 monitor can be used with tractors that are not ISOBUS compatible. Operator settings, such as bale diameter and knife activation, are accessed via the monitor. Operator warnings, left-right indicator, maximum bale size and operator information, including bale diameter and number of bales, are also provided.



CCI 200 (ISOBUS Balers)

The ISOBUS compatible CCI 200 monitor has a large 8 1/2" color screen with outstanding clarity. Baling adjustments can be easily made via the touch screen or by using the large, soft-touch keys. The CCI 200 monitor can be used with many other ISOBUS compatible machines on the market.



VT 50 (ISOBUS Balers)

The KUHN ISOBUS VT 50 monitor has a 5 3/4" color screen with outstanding clarity. Adjustments can easily be made by the touch screen and the large soft-touch keys on the sides. The VT 50 monitor can only be used specifically with the KUHN ISOBUS machines.



AT-10 (Non ISOBUS compatible)

The KUHN AT-10 monitor provides clear, easy to read information and gives full command of the baling process. An audible and visual alarm signals when the bale is ready. A choice of automatic or manual start of the tying process can be preselected. Adjustments, like the number of net wraps, are easily controlled from the tractor seat. AT-10 also provides a daily and total bale counter.

OPTIONS

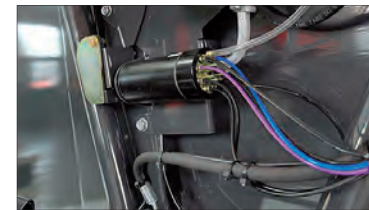

Automatic chain oiling system allows individual adjustment of the amount of oil on each chain



The second drive roller secures bale rotation even in difficult crops (standard on the VBP and optional on the VB)



Proportional valve gives in-cab control of diameter, core and pressure settings



Pivoting pickup wheels for extreme conditions to ease wheel and tire stress



3D wrapping distributes film more more uniformly and efficiently across the entire surface of the bale (VBP only)



Small bale kit allows you to wrap bales with a diameter of 31.5" and up (VBP only)



Bale turner gently places the bale on a flat end during unloading (VBP only)



Model Specifications

	VB 2255 AT-10 OPTIFLOW	VB 2285 AT-10 OPTIFLOW	VB 2260 ISOBUS OPTIFLOW	VB 2290 ISOBUS OPTIFLOW	VB 2255 AT-10 OPTIFEED	VB 2285 AT-10 OPTIFEED	VB 2260 ISOBUS OPTIFEED	VB 2290 ISOBUS OPTIFEED	VB 2260 ISOBUS OPTICUT 14	VB 2290 ISOBUS OPTICUT 14	VB 2265 ISOBUS OPTICUT 23	VB 2295 ISOBUS OPTICUT 23	VBP 2265 ISOBUS OPTICUT 14	VBP 2265 ISOBUS OPTICUT 23
DIMENSIONS														
Bale Size	4' x 5' (1.2 m x 1.5 m)	4' x 6' (1.2 m x 1.8 m)	4' X 5' (1.2 m X 1.5 m)	4' x 6' (1.2 m x 1.8 m)	4' x 5' / (1.2 m x 1.5 m)	4' x 6' / (1.2 m x 1.8 m)	4' x 5' / (1.2 m x 1.5 m)	4' x 6' / (1.2 m x 1.8 m)	4' x 5' / (1.2 m x 1.5 m)	4' x 6' / (1.2 m x 1.8 m)	4' x 5' / (1.2 m x 1.5 m)	4' x 6' / (1.2 m x 1.8 m)	4' x 5' / (1.2 m x 1.5 m)	4' x 5' / (1.2 m x 1.5 m)
Bale Diameter	31 1/2" – 63" (80 cm – 160 cm)	31 1/2" – 73" (80 – 185 cm)	31 1/2" – 63" (80 cm – 160 cm)	31 1/2" – 73" (80 cm – 185 cm)	31 1/2" – 63" (80 cm – 160 cm)	31 1/2" – 73" / 80 cm – 185 cm	31 1/2" – 63" (80 cm – 160 cm)	31 1/2" – 73" (80 cm – 185 cm)	31 1/2" – 63" (80 cm – 160 cm)	31 1/2" – 73" (80 cm – 185 cm)	31 1/2" – 63" (80 cm – 160 cm)	31 1/2" – 73" (80 cm – 185 cm)	31 1/2" – 63" (80 cm – 160 cm)	31 1/2" – 63" (80 cm – 160 cm)
Bale Width	47" (119 cm)		47" (119 cm)		47" (119 cm)		47" (119 cm)		47" (119 cm)		47" (119 cm)		47" (119 cm)	
Bale Chamber	- 1 Starter Roller - 2 Bale Chamber Rollers - 5 Belts		- 1 Starter Roller - 2 Bale Chamber Rollers - 5 Belts		- 1 Starter Roller - 2 Bale Chamber Rollers - 5 Belts		- 1 Starter Roller - 2 Bale Chamber Rollers - 5 Belts		- 1 Starter Roller - 2 Bale Chamber Rollers - 5 Belts		- 1 Starter Roller - 2 Bale Chamber Rollers - 5 Belts		- 1 Starter Roller - 2 Bale Chamber Rollers - 5 Belts	
Belts	Standard Lace Belts		Standard Lace Belts		- Standard Lace Belts - Optional Endless Belts		- Standard Lace Belts - Optional Endless Belts		- Standard Lace Belts - Optional Endless Belts		Standard Endless Belts		Standard Endless Belts	
Pickup Width	83" (211 cm)		83" (211 cm)		91" (231 cm)		91" (231 cm)		91" (231 cm)		91" (231 cm)		91" (231 cm)	
Number of Pickup Tine Bars	4		5		4		5		5		5		5	
Pickup Gauge Wheels	Standard Fixed Wheels		Standard Fixed Wheels		- Fixed Wheels - Pivoting Wheels		- Fixed Wheels - Pivoting Wheels		- Fixed Wheels - Pivoting Wheels		- Fixed Wheels - Pivoting Wheels		- Fixed Wheels - Pivoting Wheels	
Pickup Wind Guard	Standard Crop Roller		Standard Crop Roller		Standard Crop Roller		Standard Crop Roller		Standard Crop Roller		Standard Crop Roller		Standard Crop Roller	
Intake System	OptiFlow		OptiFlow		Std. OptiFeed with Integral Rotor & Opt. Drop Floor System		Std. OptiFeed with Integral Rotor & Opt. Drop Floor System		Std. 14-Knife OptiCut with Integral Rotor & Drop Floor System		Std. 23-Knife OptiCut with Integral Rotor & Drop Floor System		Std. 14-Knife OptiCut with Integral Rotor & Drop Floor System	Std. 23-Knife OptiCut with Integral Rotor & Drop Floor System
Bale Tying System	Twine, Net Wrap or Twine and Net Wrap System		Twine, Net Wrap or Twine and Net Wrap System		Twine, Net Wrap or Twine and Net Wrap System		Twine, Net Wrap or Twine and Net Wrap System		Twine, Net Wrap or Twine and Net Wrap System		Twine, Net Wrap or Twine and Net Wrap System		Twine, Net Wrap or Twine and Net Wrap System	
Bale Kicker	Standard		Standard		Standard		Standard		Standard		Standard		Standard	
PTO Power Requirement	62 hp – 75 hp (46 kW – 56 kW)		62 hp – 75 hp (46 kW – 56 kW)		65 hp – 85 hp (48 kW – 63 kW)		65 hp – 85 hp (48 kW – 63 kW)		70 hp – 90 hp (52 kW – 67 kW)		80 hp – 100 hp (60 kW – 75 kW)		110 hp – 130 hp (82 kW – 97 kW)	125 hp – 145 hp (93 kW / 108 kW)
PTO Speed	Standard 540 rpm		Standard 540 rpm		Standard 540 rpm		Standard 540 rpm		Standard 540 rpm		Standard 540 rpm		Standard 540 rpm	
PTO Type	CV PTO (1 3/8" - 6 Splines)		CV PTO (1 3/8" - 6 Splines)		CV PTO (1 3/8" – 6 Splines) with Cam Clutch		CV PTO (1 3/8" – 6 Splines) with Cam Clutch		CV PTO (1 3/8" – 6 Splines) with Cam Clutch		CV PTO (1 3/8" – 6 Splines) with Cam Clutch		CV PTO (1 3/8" – 6 Splines) with Cam Clutch	
Auto Chain Lubrication	Optional		Standard on High Silage Machines Optional on Build your own Machines		Standard on High Silage Machines Optional on Build your own Machines		Standard on High Silage Machines Optional on Build your own Machines		Optional		Standard Beka-Max Continuous Oiler System		Standard Beka-Max Continuous Oiler System	
Overload Protection	Shear Bolt		Shear Bolt or Cam Clutch		Cam Clutch		Cam Clutch		Cam Clutch		Cam Clutch		Cam Clutch	
Tires	<ul style="list-style-type: none"> • 11.5/80-15 • 15.0/55-17 • 19.0/45-17 		<ul style="list-style-type: none"> • 15.0/55-17 • 19.0/45-17 		<ul style="list-style-type: none"> • 15.0/80-15 • 15.0/55-17 • 19.0/45-17 		<ul style="list-style-type: none"> • 15.0/55-17 • 19.0/45-17 • 500/45-22.5 		<ul style="list-style-type: none"> • 15.0/55-17 • 19.0/45-17 • 500/45-22.5 		500/45-22.5		<ul style="list-style-type: none"> • 400/60-22.5 • 500/45-22.5 	
Electronic Monitor	AT-10 Monitor with Left & Right Indicator		- VT 50 - CCI-200 - No Monitor		AT-10 Monitor with Left & Right Indicator		- VT 50 - CCI-200 - No Monitor		- VT 50 - CCI-200 - No Monitor		- VT 50 - CCI-200 - No Monitor		- VT 50 - CCI-200 - No Monitor	
Road Lights and Signaling	Standard		Standard		Standard		Standard		Standard		Standard		Standard	
Required Tractor Hydraulic Connections	1 SA and 1 DA		1 SA and 1 DA		1 SA and 1 DA		1 SA and 1 DA		1 SA and 1 DA		2 DA		1 SA and 1 DA with a 3/4" Free Return	
Transport Width	8'1" (2.5 m)		8'1" (2.5 m)		8'1" (2.5 m)		8'1" (2.5 m)		8'1" (2.5 m)		8'1" (2.5 m)		8'10" (2.7 m)	
Minimum Machine Weight	5,400 lbs (2,450 kg)	5,510 lbs (2,500 kg)	5,510 lbs (2,500 kg)	5,620 lbs (2,550 kg)	6,400 lbs (2,900 kg)	6,500 lbs (2,950 kg)	6,615 lbs (3,000 kg)	6,055 lbs (2,750 kg)	7,165 lbs (3,250 kg)	7,500 lbs (3,400 kg)	6,615 lbs (3,000 kg)	7,605 lbs (3,550 kg)	12,550 lbs (5,700 kg)	12,550 lbs (5,700 kg)



COMPLEMENTARY PRODUCTS

MORE PRODUCTS TO MEET YOUR NEEDS

With over 700 models of equipment, we have the most complete implement line in the industry. Whether you have a small or large operation, we have a broad range of models and options to help fit your diverse needs.



1. Wheel Rakes
2. Mower Conditioners
3. Square Balers
4. Bale Wrappers
5. Bale Processors
6. TMR Mixers

For more information about your nearest KUHN dealer and other KUHN products, visit our website

www.KuhnNorthAmerica.com



Visit our YouTube channel to watch our latest product videos.

 www.KuhnNorthAmerica.com	Your KUHN dealer
---	------------------

KUHN NORTH AMERICA, INC.

Corporate Headquarters
1501 West Seventh Avenue - Brodhead, WI 53520
Phone: (608) 897-2131 Fax: (608) 897-2561

Information given in this document is only for informational purposes and is non-contractual. Our machines are in compliance with North American safety standards. In our literature, and for improved illustration of certain details, some safety devices may not be in operating position. When operating these machines, these devices must be operated in accordance with the requirements indicated in the operator's manuals and assembly manuals. We reserve the right to change any designs, specifications or materials listed without further notice. Machines and equipment in this document can be covered by at least one patent and/or registered design. Trademarks cited in this document may be registered in one or several countries.

Find us on

