

19 — 21 — 23 — 25 — 26.5



KOHLER[®]
COMMAND PRO[®] **EFI**
19-26.5 HP

KOHLER[®] Engines

SAVE UP TO \$600 A YEAR ON FUEL.*

**CELEBRATE
AT WILL.**

We're talking up to \$600-a-year fuel savings.* And that's per engine. So imagine the savings on a fleet of ZTRs. If you want lower operating costs and less downtime, the fuel-sipping KOHLER® Command PRO® EFI is your engine. Closed-loop electronic fuel injection saves gas and covers more ground. And pays for itself in a year or less.**

*Compared to a comparable KOHLER carbureted engine under comparable loads and duty cycles.

**Based on 600 hours of annual operation.

Do the math. And see how much you'll save.

Price of gasoline per gallon	\$3.00	\$3.25	\$3.50	\$3.75	\$4.00	\$4.25	\$4.50	\$4.75	\$5.00	\$5.25	\$5.50	\$5.75
KOHLER Closed-Loop EFI												
Dollars saved per hour	\$0.90	\$0.98	\$1.05	\$1.13	\$1.20	\$1.28	\$1.35	\$1.43	\$1.50	\$1.58	\$1.65	\$1.73
Dollars saved in first year	\$540	\$585	\$630	\$675	\$720	\$765	\$810	\$855	\$900	\$945	\$990	\$1,035

Data based on 25% fuel savings and 600 hours of annual operation per mower.

A person is shown from behind, mowing a lawn with a riding mower. The mower is dark-colored with a large, curved blade. The background is a soft-focus landscape with green grass and a hazy sky. The overall tone is professional and practical.

KOHLER Command PRO[®] EFI

⊕ HUGE SAVINGS

- Saves up to \$600 a year on fuel, with less downtime for refueling.*
- No carburetor – no carburetor maintenance or replacement costs.

*Compared to a comparable KOHLER carbureted engine under comparable loads and duty cycles. Based on 600 hours of annual operation.

⊕ MORE RELIABLE

- No carburetor – no carburetor problems.
- No choking and no priming.
- 3-year unlimited-hour commercial warranty.

⊕ EXCLUSIVE CLOSED-LOOP TECHNOLOGY

- Only closed-loop EFI engine in its class, more fuel-efficient than open-loop systems.*
- ECU and O₂ sensor automatically optimize fuel mixture based on load, weather and altitude.
- Closing the loop between air/fuel intake and exhaust output provides more power and fuel savings.

*Engine class being twin-cylinder, general-purpose gasoline engines.

⊕ EASY START

- Starts like your car – just turn the key and go.
- No-choke starting whether it's hot, cold or after extended storage.
- High-energy electronic ignition for quick and reliable starts.

⊕ REAL-TIME TROUBLESHOOTING

- EFI Diagnostic Software provides instant data on engine performance.
- Works where you are – in the field, in the shop, anywhere.

KOHLER® COMMAND PRO® EFI ENGINE ARCHITECTURE

19-26.5-HP VERTICAL-SHAFT ENGINES HEAVY-DUTY AIR CLEANER

TOP VIEW

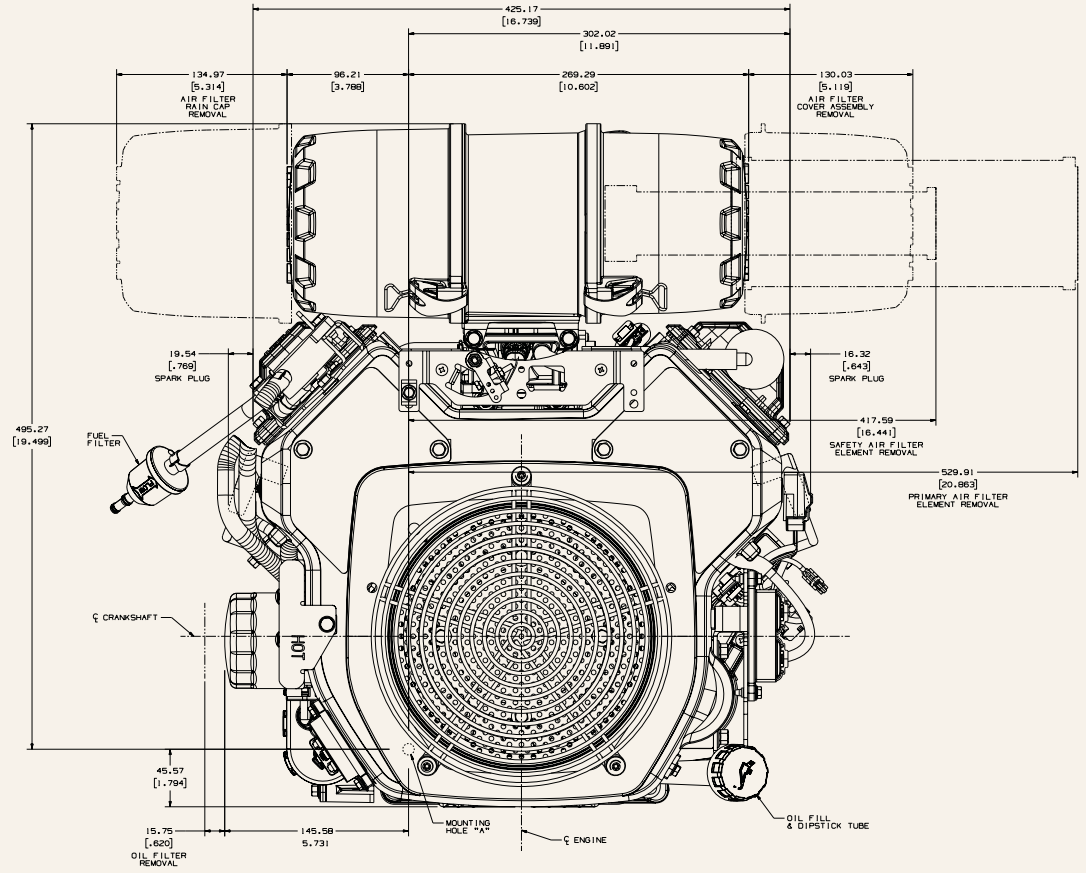

STARTER SIDE

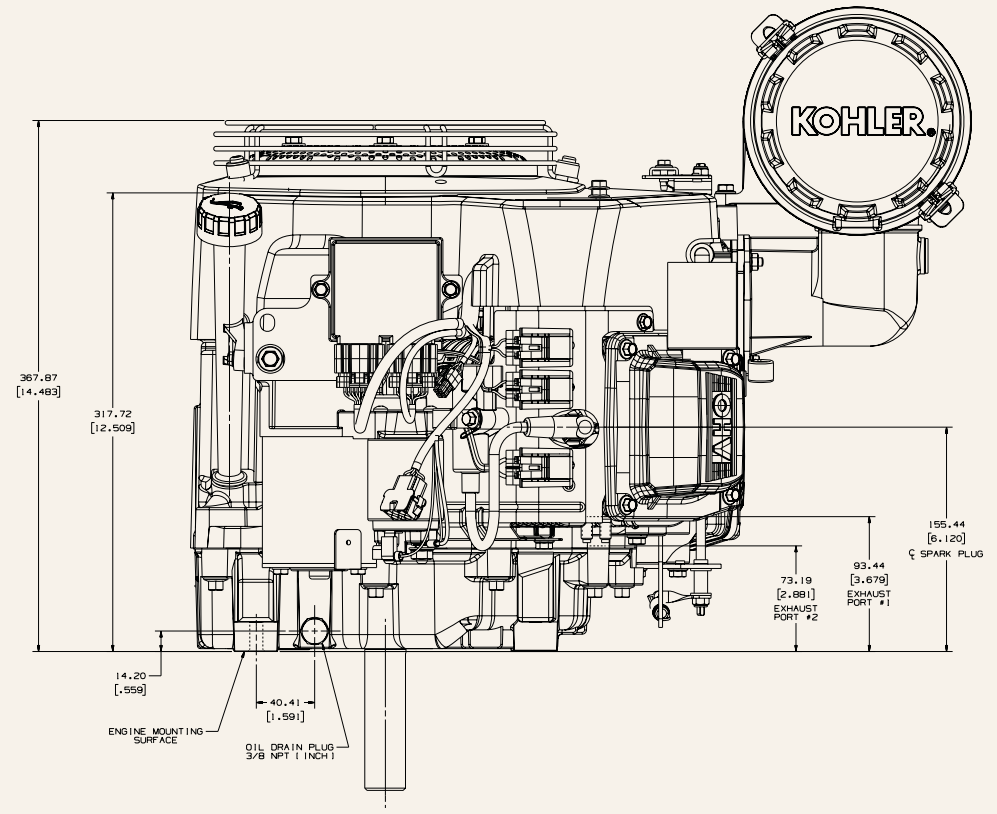

19-26.5-HP VERTICAL-SHAFT ENGINES HEAVY-DUTY AIR CLEANER

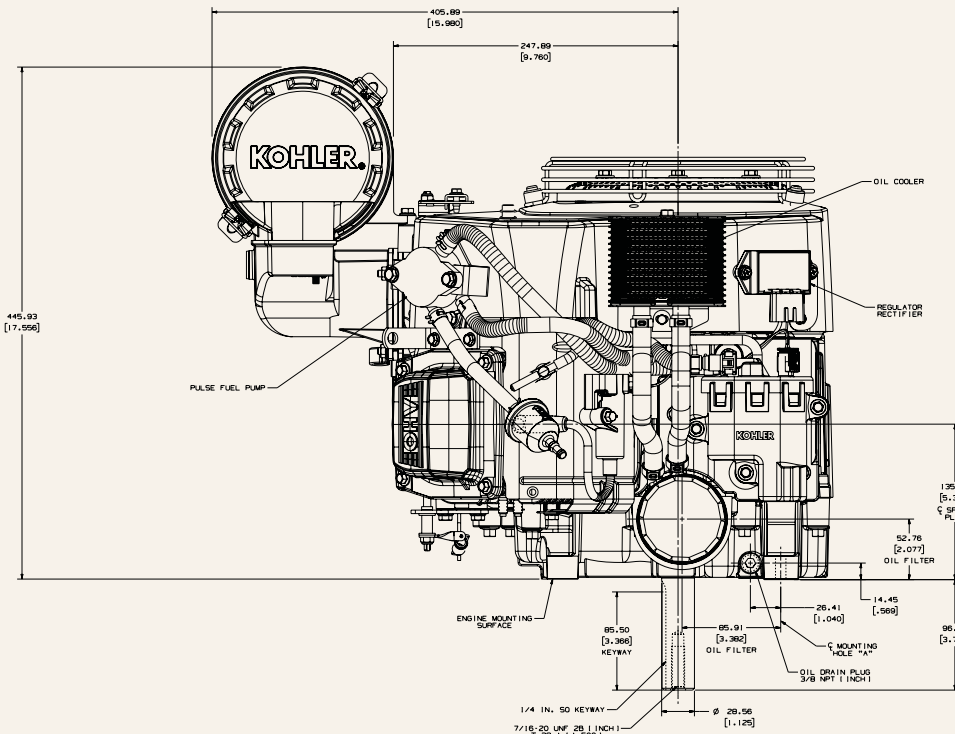
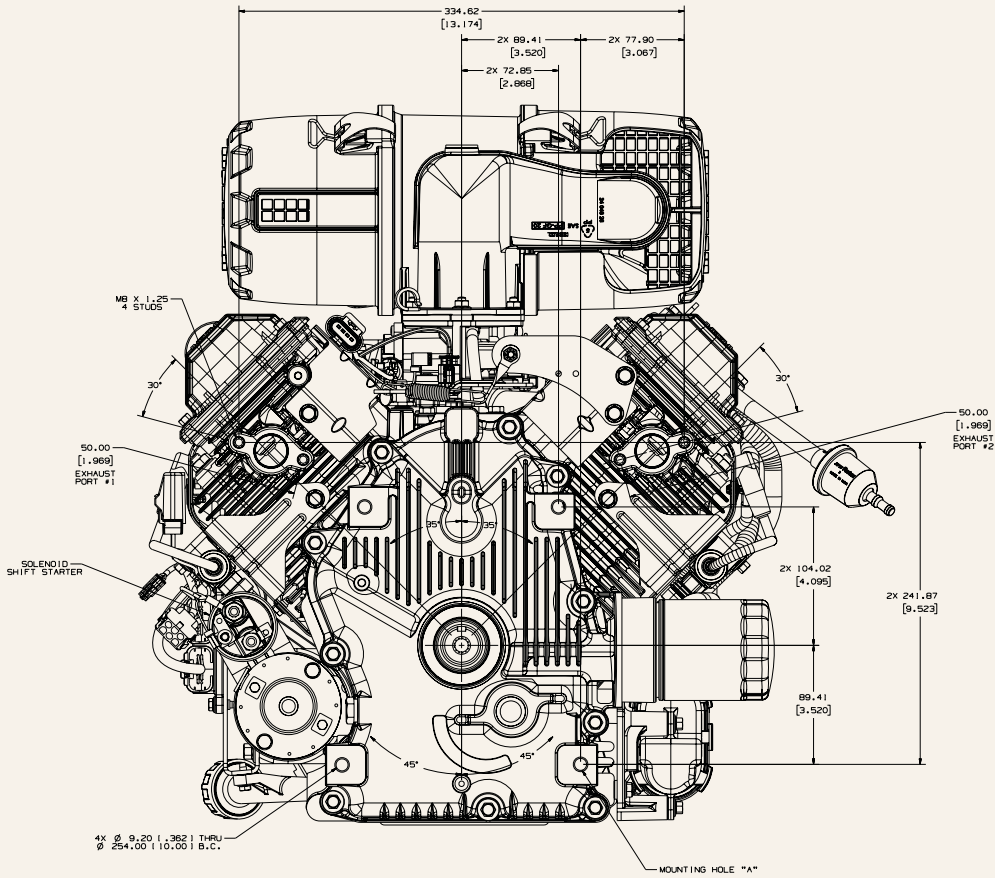

MAXIMUM POWER

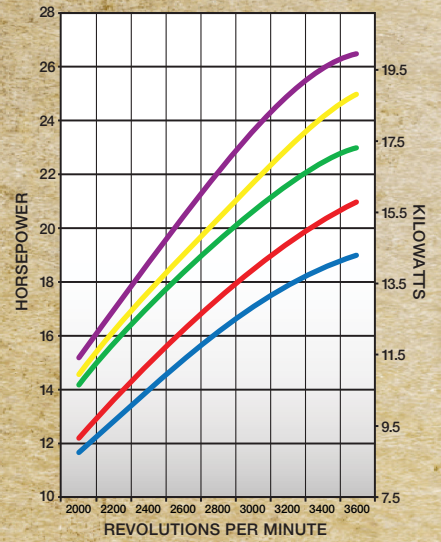

MAXIMUM TORQUE

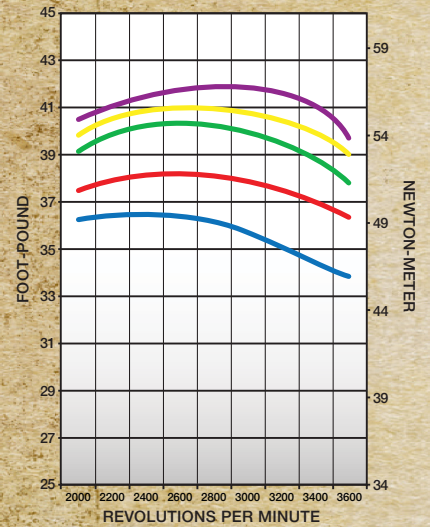

■ ECV630 ■ ECV650 ■ ECV730
■ ECV740 ■ ECV749

**RATED AT 3600 RPM
PER SAE J1940 GROSS**

KOHLER® COMMAND PRO® EFI ENGINE ARCHITECTURE

19-26.5-HP VERTICAL-SHAFT ENGINES LOW-PROFILE AIR CLEANER

TOP VIEW

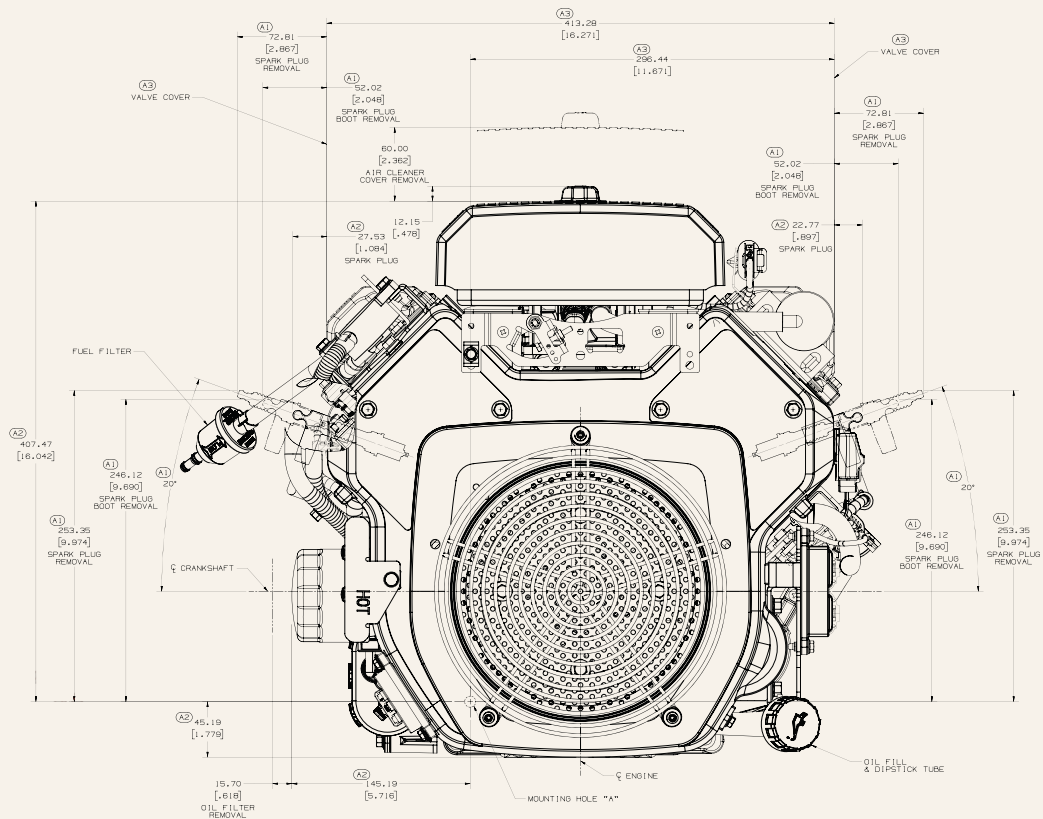

STARTER SIDE

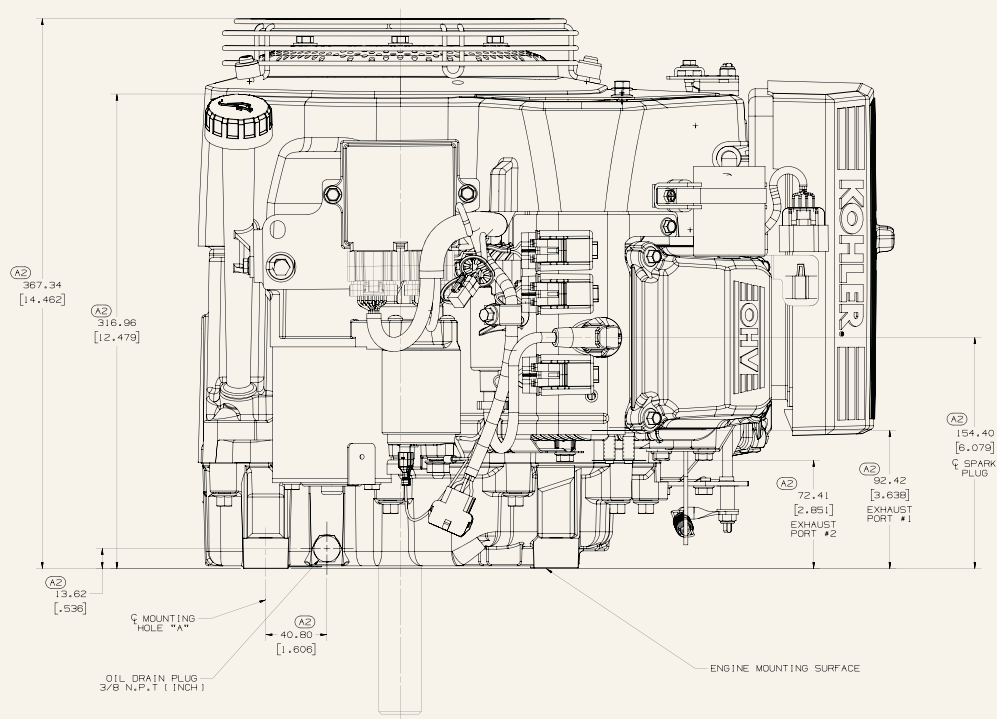

19-26.5-HP VERTICAL-SHAFT ENGINES LOW-PROFILE AIR CLEANER

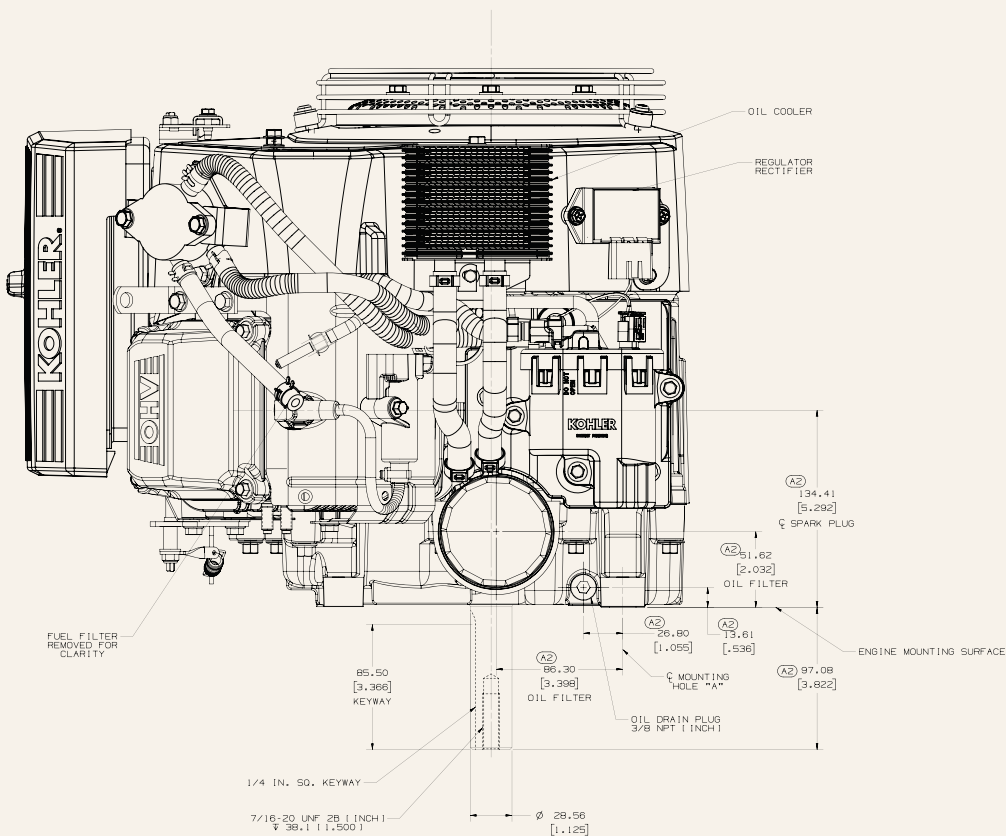
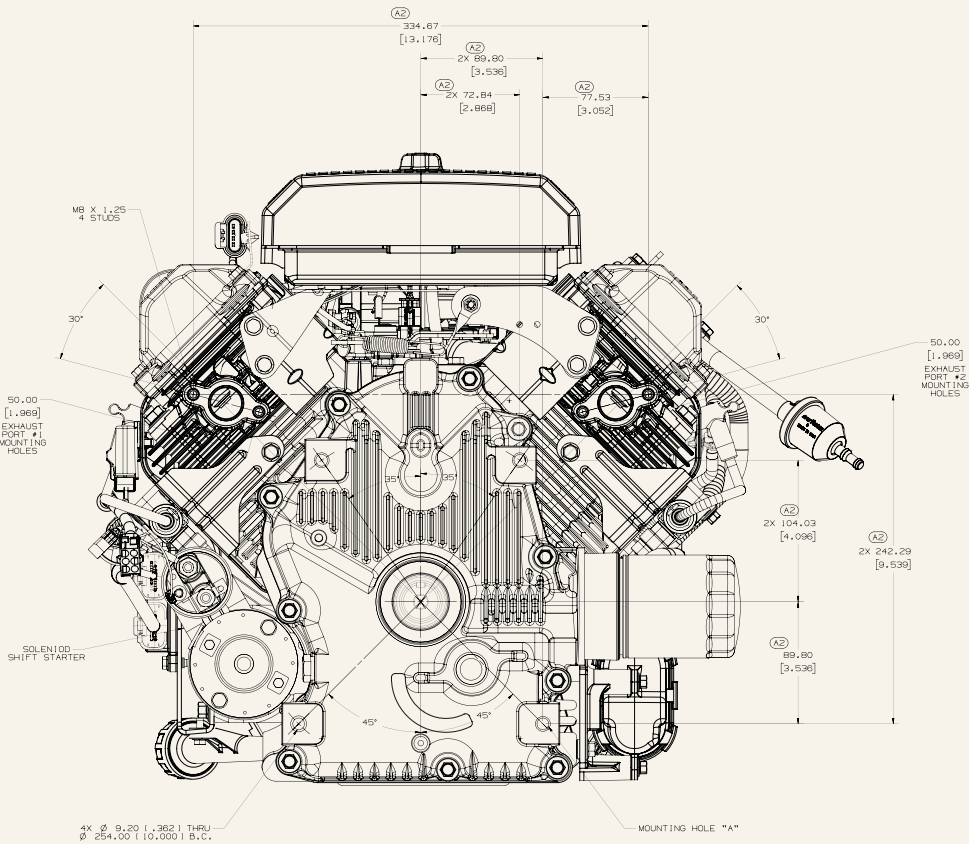

KOHLER® COMMAND PRO® EFI ENGINE ARCHITECTURE

19-26.5-HP HORIZONTAL-SHAFT ENGINES HEAVY-DUTY AIR CLEANER

FRONT VIEW

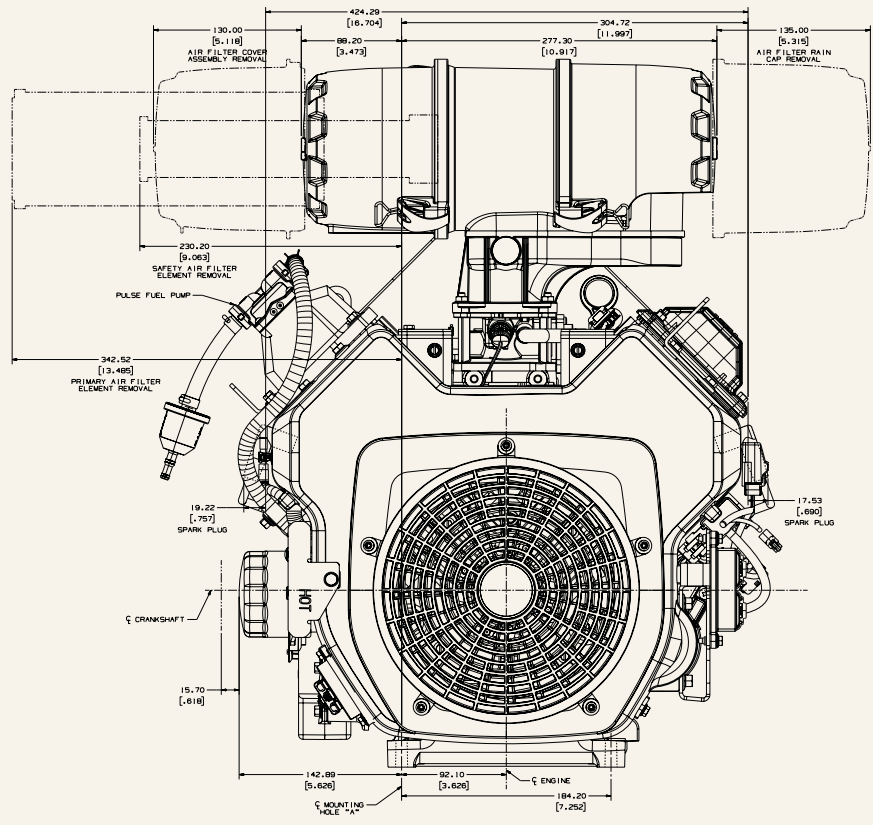

STARTER SIDE

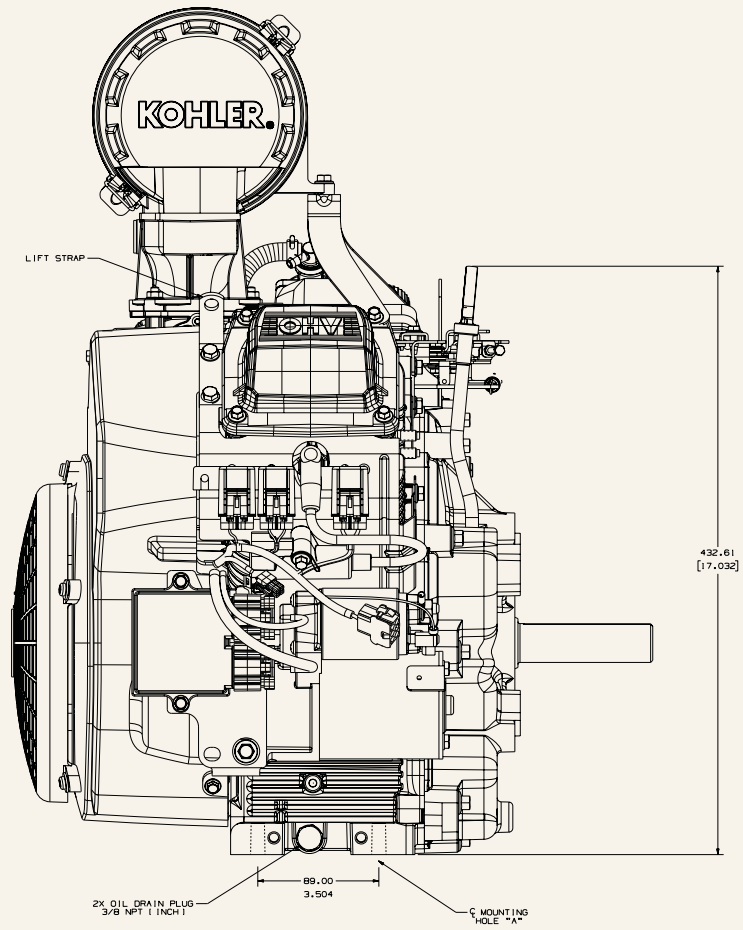

19-26.5-HP HORIZONTAL-SHAFT ENGINES HEAVY-DUTY AIR CLEANER

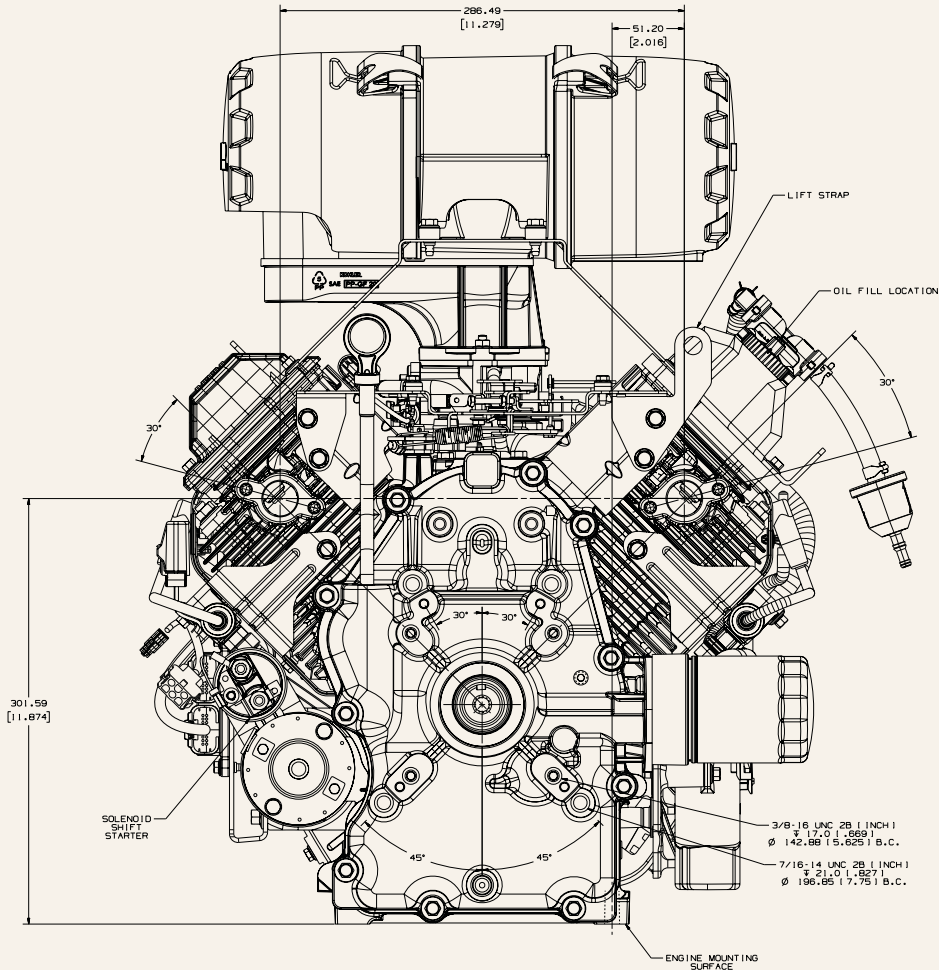

PTO VIEW

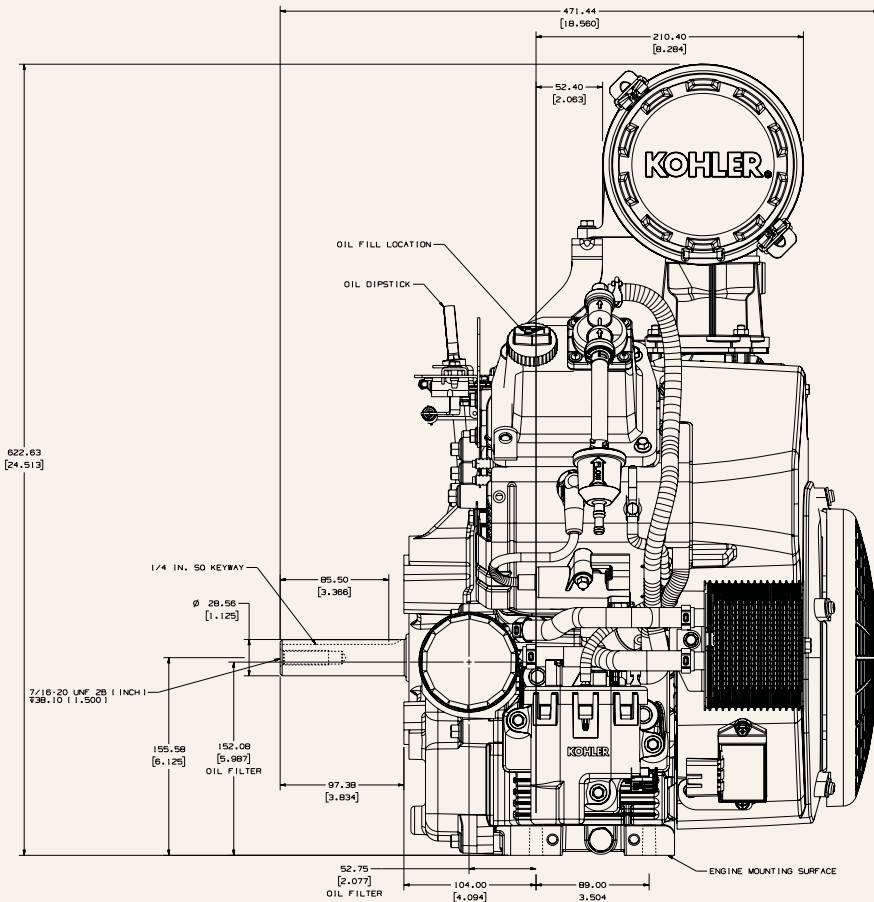

OIL FILTER SIDE

MAXIMUM POWER

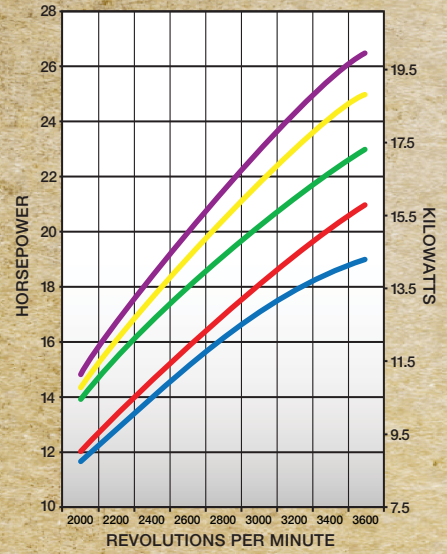

MAXIMUM TORQUE

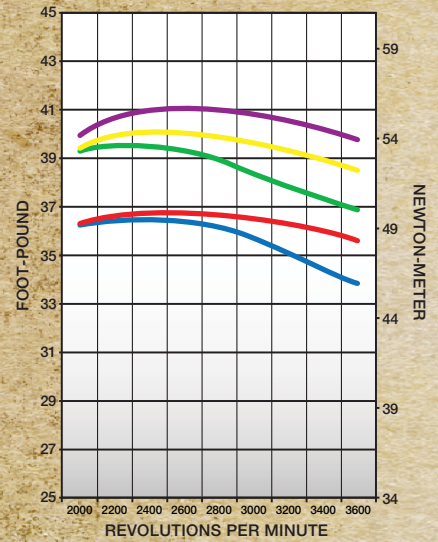

ECH630 ECH650 ECH730
ECH740 ECH749

RATED AT 3600 RPM
PER SAE J1940 GROSS

KOHLER® COMMAND PRO® EFI ENGINE ARCHITECTURE

19-26.5-HP HORIZONTAL-SHAFT ENGINES LOW-PROFILE AIR CLEANER

FRONT VIEW

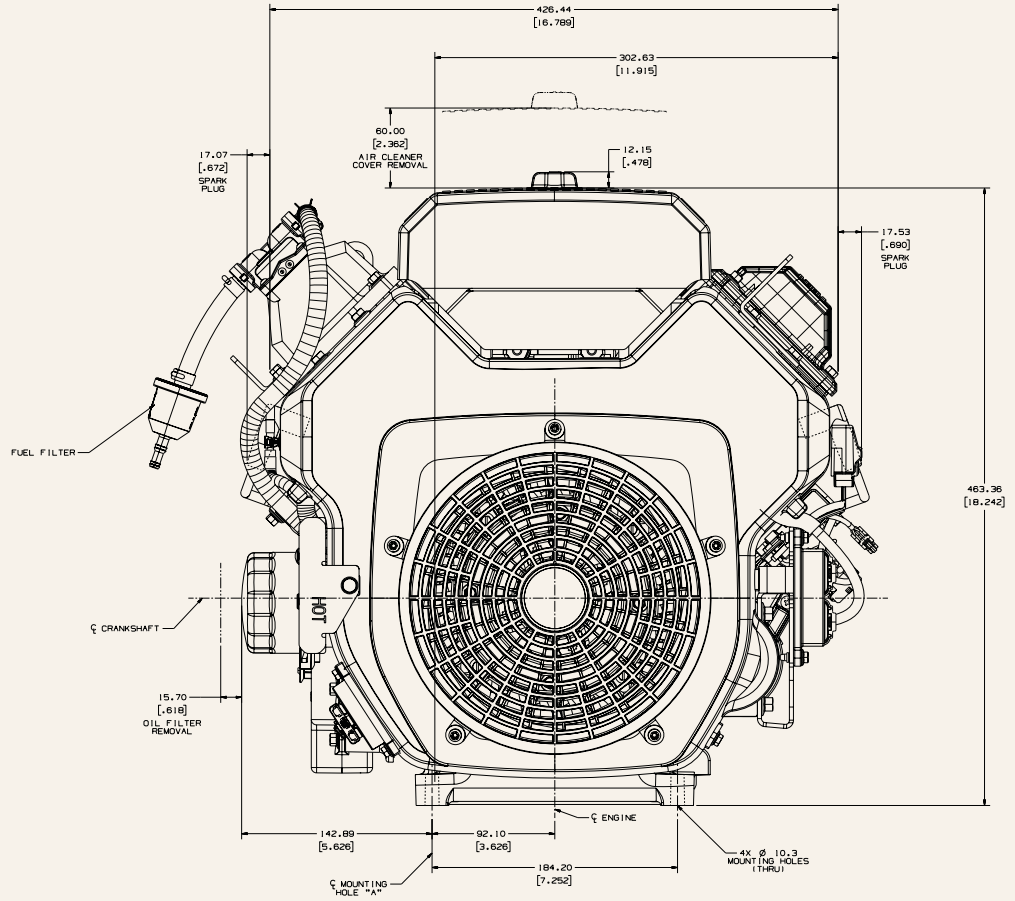

STARTER SIDE

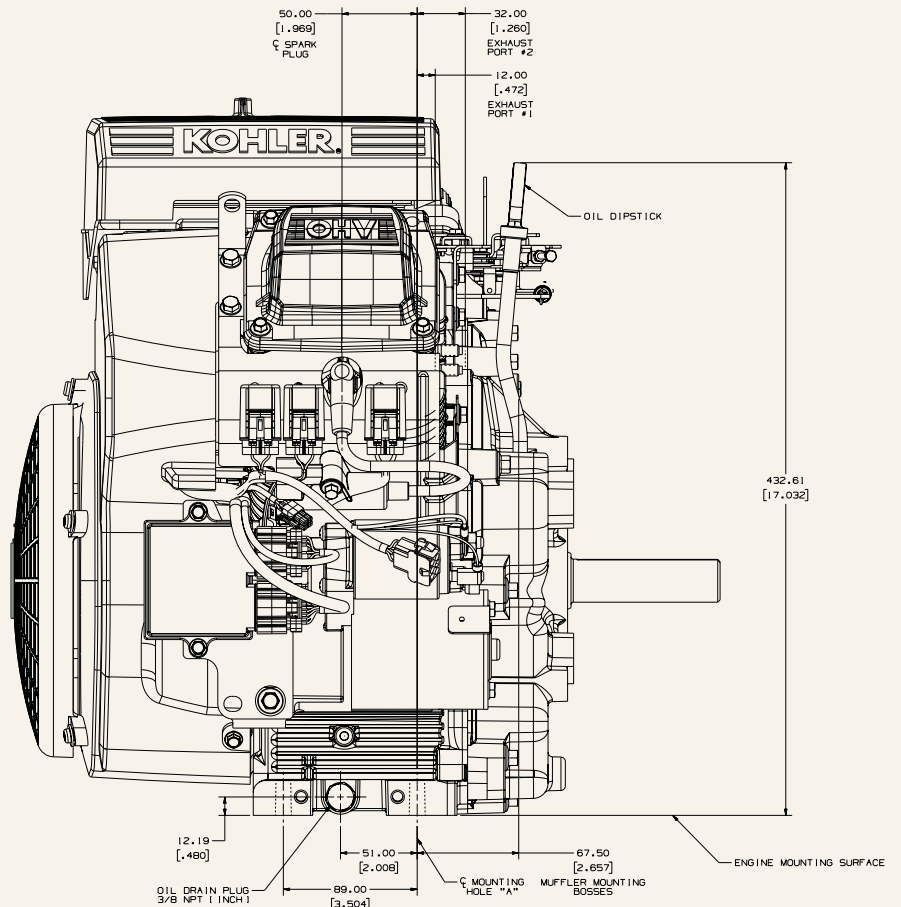

19-26.5-HP HORIZONTAL-SHAFT ENGINES LOW PROFILE AIR CLEANER

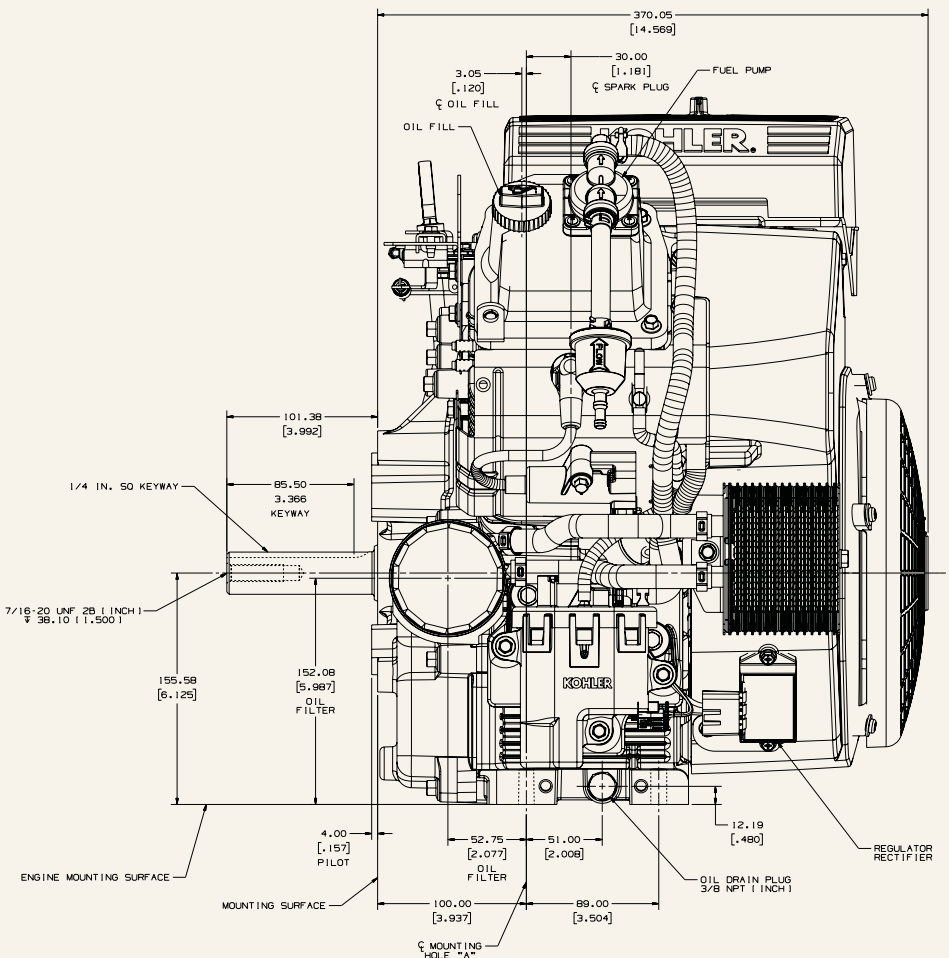
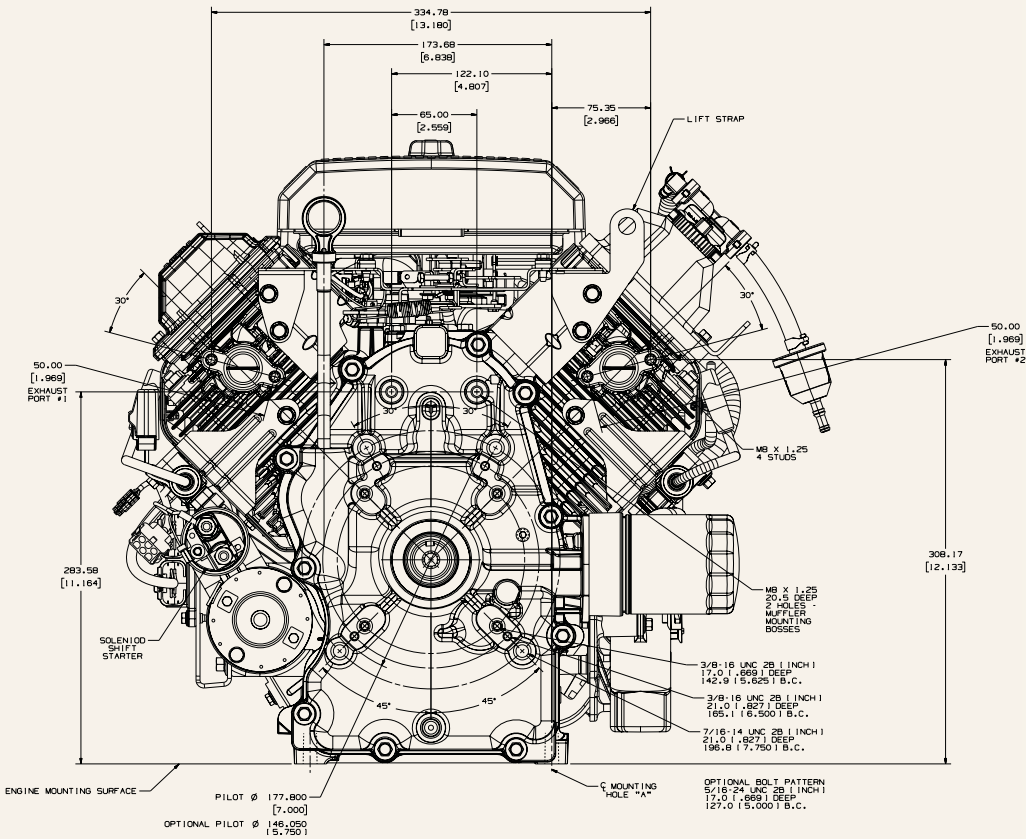

KOHLER Command Pro® EFI

Model	ECH/ECV630	ECH/ECV650	ECH/ECV730	ECH/ECV740	ECH/ECV749
*Power @ 3600 rpm Max. hp (kW)	19 (14.2)	21 (15.7)	23 (17.2)	25 (18.6)	26.5 (19.8)
Displacement cu in (cc)	42 (694)		45 (747)		
Bore in (mm)	3.2 (80)		3.3 (83)		
Stroke in (mm)	2.7 (69)				
Peak Torque @ Maximum rpm CH ft lb (Nm)	34.2 (46.4) @2200	34.5 (46.8) @2600	38.1 (51.7) @2200	38.8 (52.6) @2400	40.0 (54.2) @2600
Peak Torque @ Maximum rpm CV ft lb (Nm)	34.2 (46.4) @2200	36.4 (49.4) @ 2600	39.1 (53.0) @2600	39.9 (54.1) @2400	40.9 (55.5) @3000
Compression Ratio	8.7:1		9.1:1		
Dry Weight lb (kg)	108 (49)				
Oil Capacity U.S. qt (L)	2 (1.9)				
Lubrication	Full-pressure with full-flow filter				
Dimensions L x W x H in (mm)	a/b				
**a = CH	flat air cleaner	14.6(371) x 18.2 (462) x 18.7 (475)			
	heavy-duty air cleaner	14.8 (376) x 18.9 (480) x 24.5 (622)			
***b = CV	flat air cleaner	17.9 (455) x 18.3 (465) x 14.5 (368)			
	heavy-duty air cleaner	21.3 (541) x 18.5 (470) x 17.6 (447)			

* Horsepower ratings meets Society of Automotive Engineers Small Engine Test Code J1940. Actual engine horsepower is lower and affected by, but not limited to, accessories (air cleaner, exhaust, charging, cooling, fuel pump, etc.), application, engine speed and ambient operating conditions (temperature, humidity and altitude). For more information, contact Kohler Co. Engine Engineering. Kohler reserves the right to change product specifications, designs and equipment without notice and without incurring obligation.

** L = grass screen to PTO mounting face W = spark plug to spark plug H = top of air cleaner cover to mounting feet

*** L = blower housing to air cleaner cover W = spark plug to spark plug H = top of air cleaner cover to mounting surface

Standard Features

- Closed-loop electronic fuel injection
- 20-amp charging, regulated
- Yellow oil cap and dipstick
- Large filters (air, oil, fuel)
- Hardened crank journals
- PTO side-load sleeve bearing
- Hydraulic valve lifters
- 12-volt solenoid shift electric start
- Dual-element air cleaner
- Dual oil drains
- Electronic ignition
- Solenoid fuel shutdown
- Oil Sentry™ automatic warning/shutdown system (installed, not wired)
- Full-pressure lubrication/full-flow filter

3-Year Limited Warranty

Popular Factory Options

- Remote oil filter
- Variety of mufflers
- Exhaust deflector/spark arrestor
- Engine-mounted controls (CH)
- 5 percent governor
- SAE A/B pump mounts
- Choice of air cleaners (flat, HD, WAWB)
- Guard for rotating grass screen
- Chopper-type grass screen
- Additional crank sizes
- Flywheel PTOs
- Oil Cooler

For more information, contact your KOHLER source of supply.
Or call toll-free in the U.S. and Canada 800-544-2444.

Kohler Co., Kohler, Wisconsin 53044 Tel 920-457-4441 Fax 920-459-1570

KohlerEngines.com

© 2013 by Kohler Co. All rights reserved.

Kohler® and Command PRO® are trademarks of Kohler Co.

KOHLER Engines