

KOHLER Courage®

15-27 hp Engines



KOHLER®



KOHLER®

PERFORMANCE
ENGINEERING

Every part, every component, every system on a KOHLER® engine is guided by our exclusive Performance Engineering standards – standards that drive us to operate on the leading edge of innovation, to push the boundaries of cleaner, more efficient engines, and to manufacture the most reliable engines on the market. That's Performance Engineering.



KOHLER® Courage® – Professional-grade
engineering for the consumer.

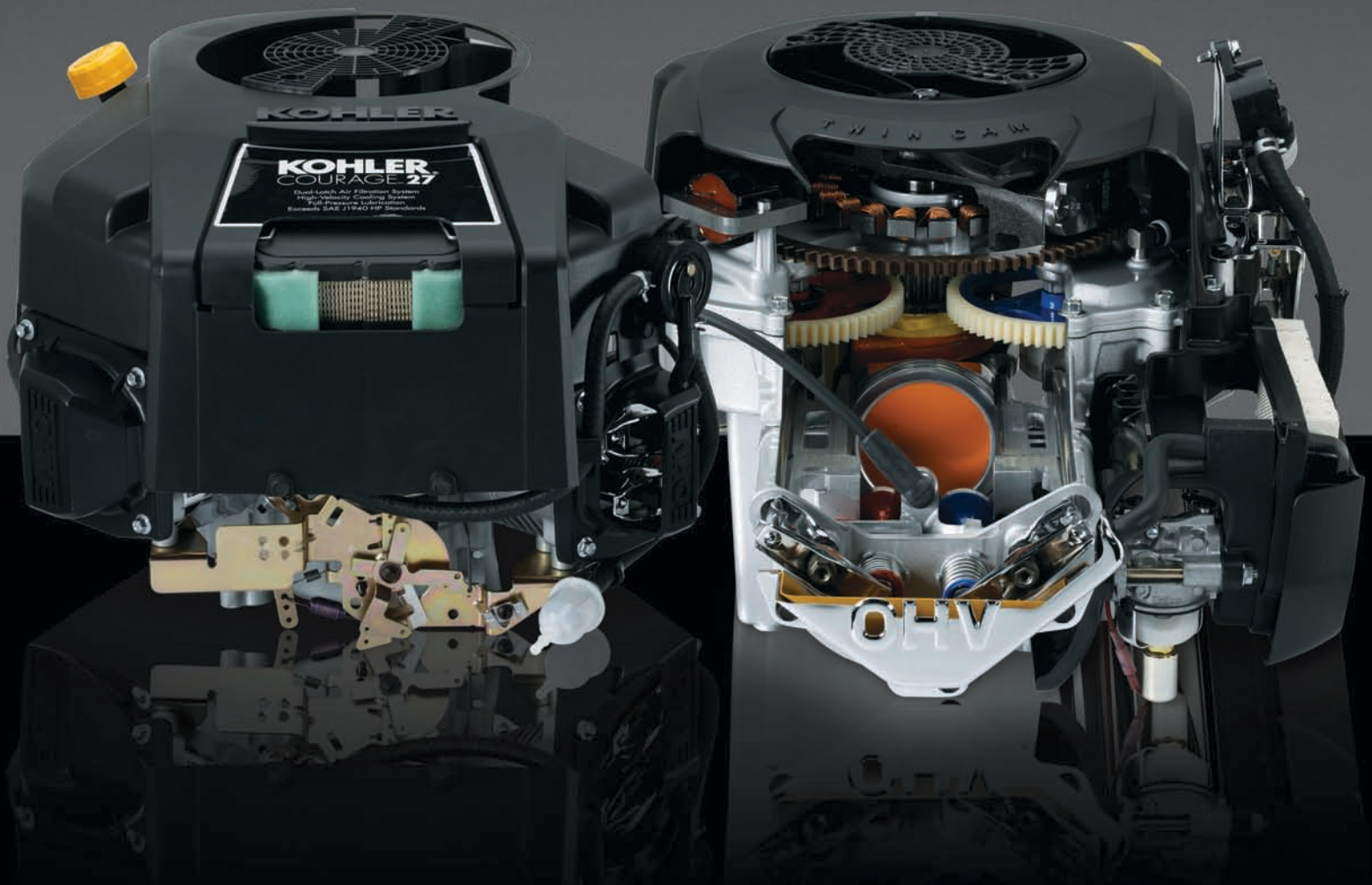

Today, more and more consumers are demanding professional-grade products. Products that deliver power, performance and convenience. And KOHLER® Courage gives it to them. Introducing the first KOHLER engine designed specifically for consumer applications, Courage® delivers more displacement, across the board, for more power. Easier starts; reduced noise, vibration, emissions and fuel consumption – it's what professionals have come to expect from KOHLER and what today's informed consumer market demands.



Overhead Valve.

Engines featuring an overhead valve (OHV) design deliver smoother running, more fuel efficient performance. Because of the increased volumetric efficiency, an OHV engine will produce more torque per unit of displacement than a side valve engine. The life of an OHV engine is also longer because the design allows greater airflow around the cylinder head keeping the engine cooler and reducing oil consumption.

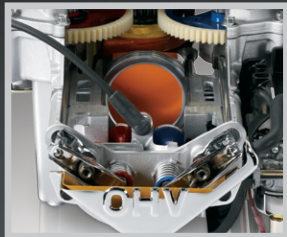

Cast-Iron Cylinder Bore.

Further extending engine life, cast-iron liners provide added protection under extreme load and dirty operating conditions.

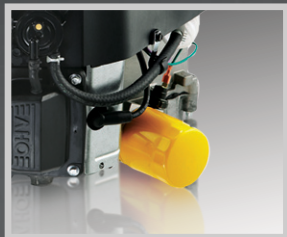

Full-Pressure Lubrication with Oil Filter and Bypass Valve.

Full pressure lubrication is standard on all KOHLER Courage engines. Oil is distributed continuously, and a full-flow oil filter protects critical rotating parts for longer engine life. The high-efficiency Gero oil pump ensures lubrication to critical components.

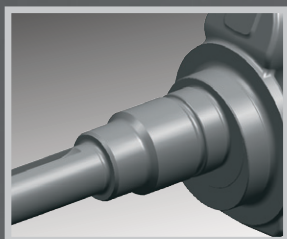

Oversized and Micro-Polished Crankshaft Bearings.

Extra protection in high load conditions to ensure uniform distribution of oil in critical bearings and prevent wear, resulting in longer engine life.



Consistent-Cut™ Technology.

Kohler Consistent-Cut™ technology delivers consistent power to your deck across a wide range of loads, allowing the user to cut through thick, wet grass conditions that stall the competition.



KOHLER® Courage Singles

The engine that's taking the consumer lawn and garden market by storm. The KOHLER Courage® single-cylinder engine delivers more horsepower and greater displacement than any engine in its class. With patented features like a crossflow cylinder head, a dual-reciprocating balance valve, an inverted crankcase and a twin-cam design, Courage gives consumers the power and response that makes KOHLER the brand of choice for professionals.

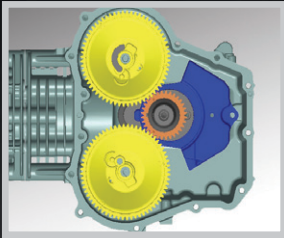

Twin-Cam Design*

Delivers responsive power and opens the cylinder head for superior cooling, resulting in longer life and reliability.

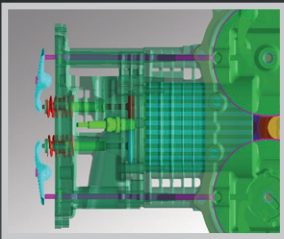

Crossflow Cylinder Head*

The twin cam separates the valve assembly, opening up the head for greater airflow and a cooler running engine. A cooler engine – with less bore distortion – offers lower oil consumption, longer life and more useable power.

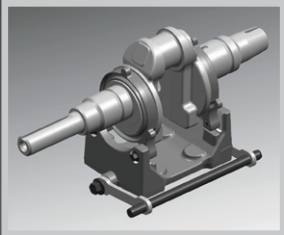

Dual-Reciprocating Balance System*

An advanced KOHLER balance system provides smooth, comfortable operation.

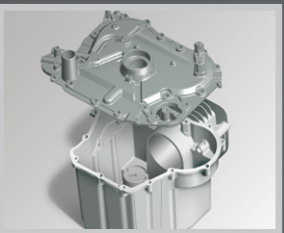

Inverted Crankcase*

This unique configuration ensures leakproof operation and no-mess oil filter removal.

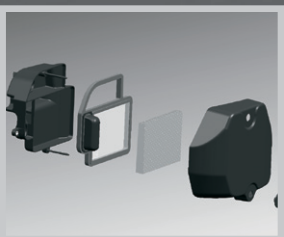

Tri-Phase Acoustically Dampened Air Induction

System dampens intake noise which results in quieter operation.

*Kohler Patents

15-22 hp vertical-shaft engines

KOHLER® COURAGE® ENGINE ARCHITECTURE

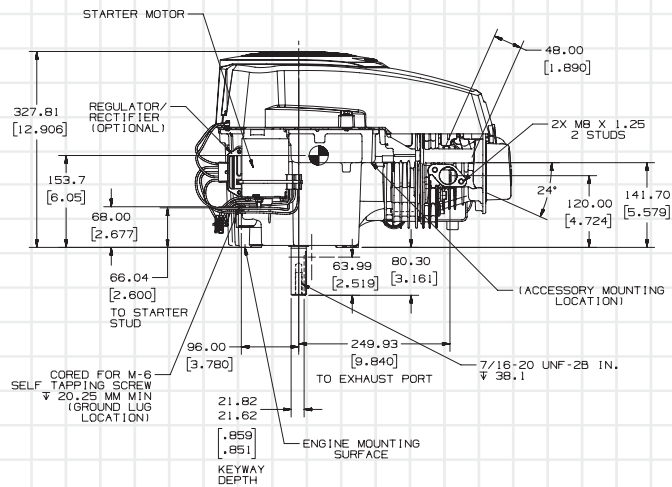
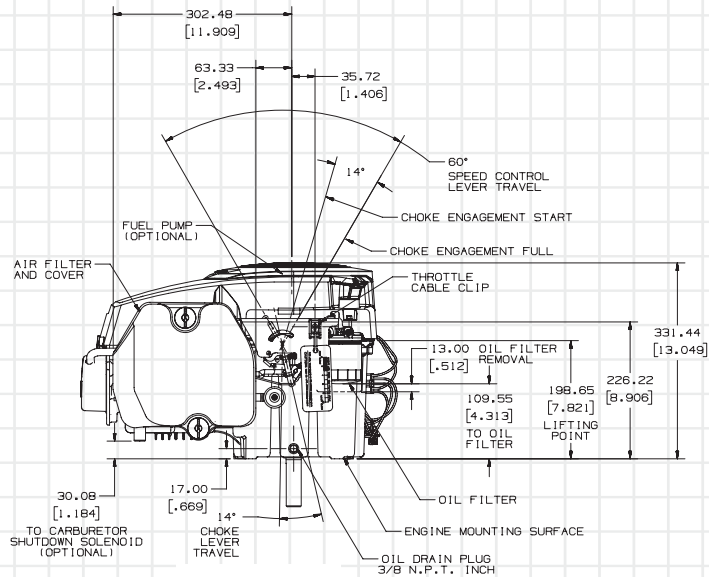
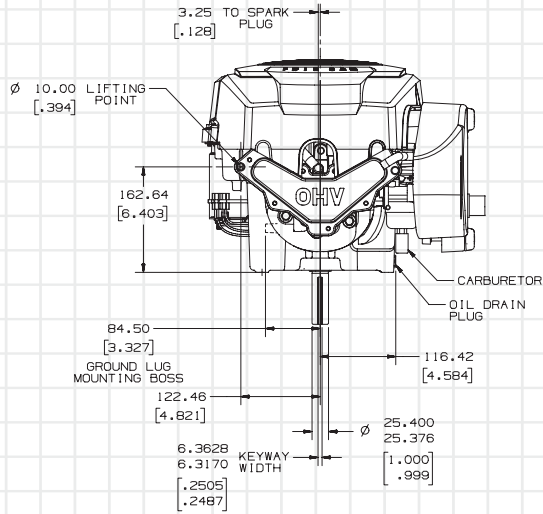

▶ VALVE COVER VIEW

AIR CLEANER VIEW ▶

STARTER VIEW ▶

15-22 hp vertical-shaft engines

TOP VIEW

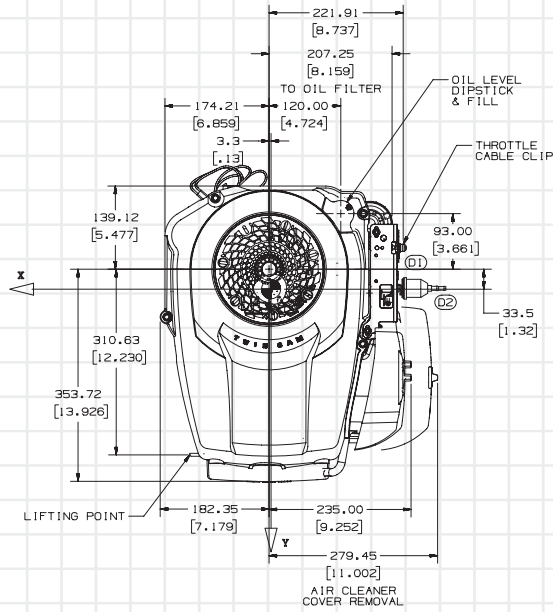

PTO VIEW

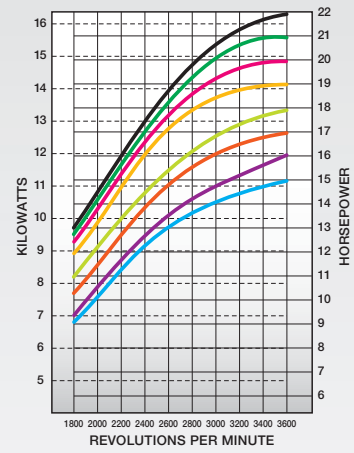
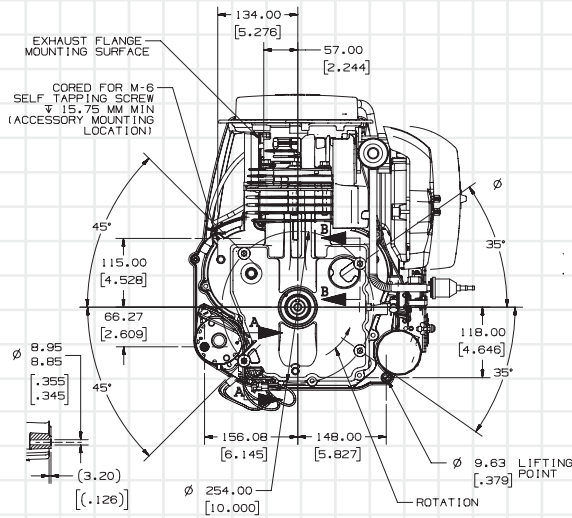

Maximum Power

- SV620
- SV610
- SV600
- SV590
- SV540
- SV530
- SV480
- SV470

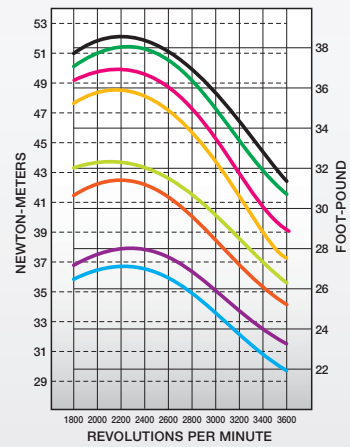

Maximum Torque

Engines that set the standard.



Emissions:

Certified for both EPA and California emissions standards. Precise air-to-fuel ratio for cleaner combustion with optimum horsepower and torque.

Service:

Backed by more than 13,000 dealers and distributors worldwide.

Warranty:

Two-year limited warranty covering all consumer applications.

KOHLER® Courage Twins

KOHLER – the power more professionals demand – delivers even more power for the consumer lawn and garden market. The KOHLER Courage® twin-cylinder, vertical-shaft, OHV engines from 20 to 27 hp. Power. Performance. Convenience. Just what you expect from KOHLER.



V-Twin Design.

Provides reduced vibration of higher-powered engines for smooth, comfortable operation.

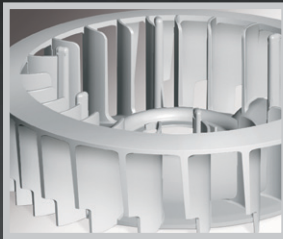

Modulated Cooling Fan.

Variable fin spacing reduces noise and optimizes air flow resulting in longer engine life.

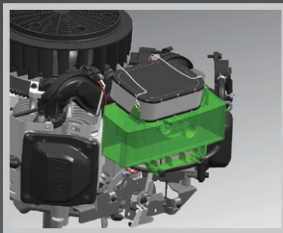

Acoustically Dampened Air Induction.

System dampens intake noise which results in quieter operation.



Dual-Seal, Top-Mount Air Filter.

Easy-access air filter allows for quick inspection and changes. Dual seal ensures no debris gets into the engine.



High-Torque Inertia Drive Starter.

Extra-large output starter ensures quick, reliable starting in all conditions.



20-27 hp vertical-shaft engines

VALVE COVER VIEW

STARTER SIDE VIEW

OIL FILTER VIEW

KOHLER® COURAGE™ ENGINE ARCHITECTURE

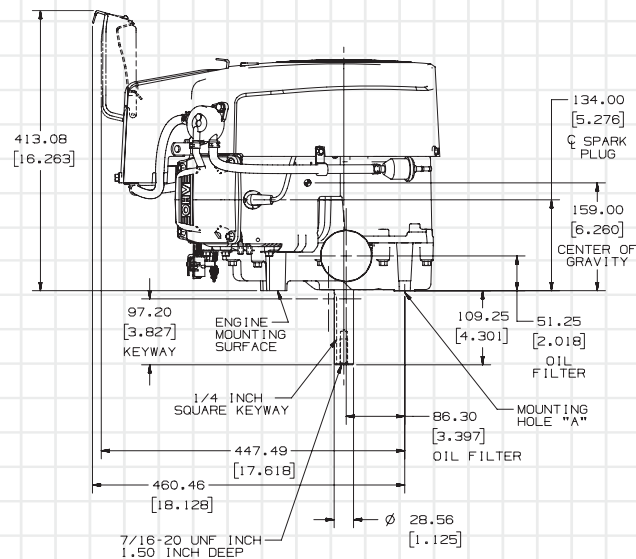
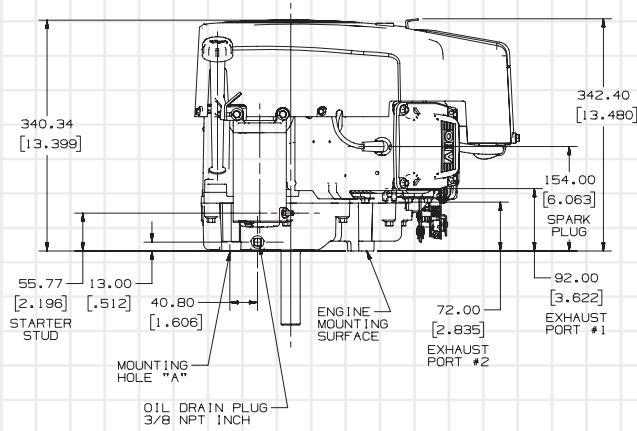
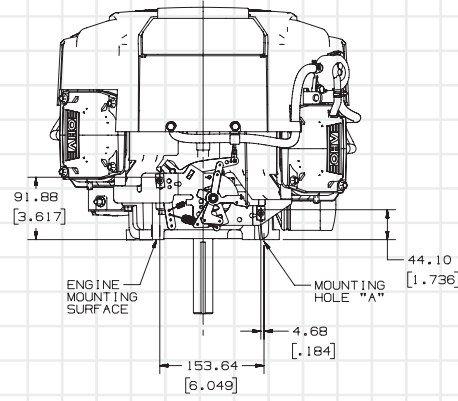

20-27 hp vertical-shaft engines

TOP VIEW

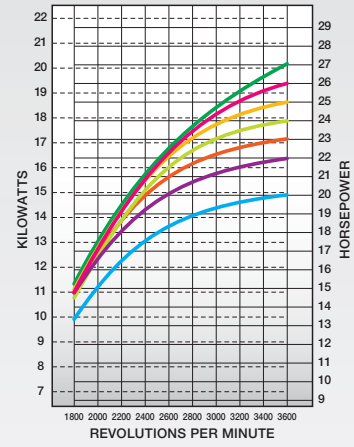
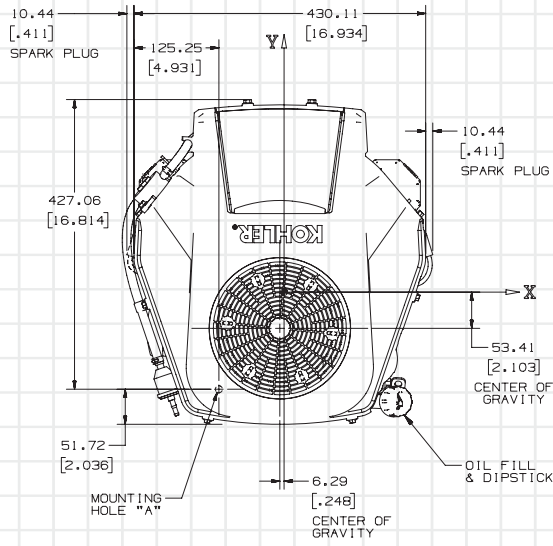

Maximum Power

- SV740
- SV735
- SV730
- SV725
- SV720
- SV715
- SV710

PTO VIEW

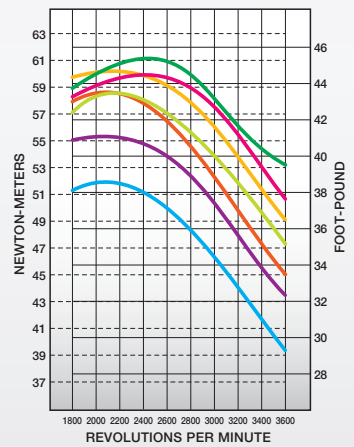
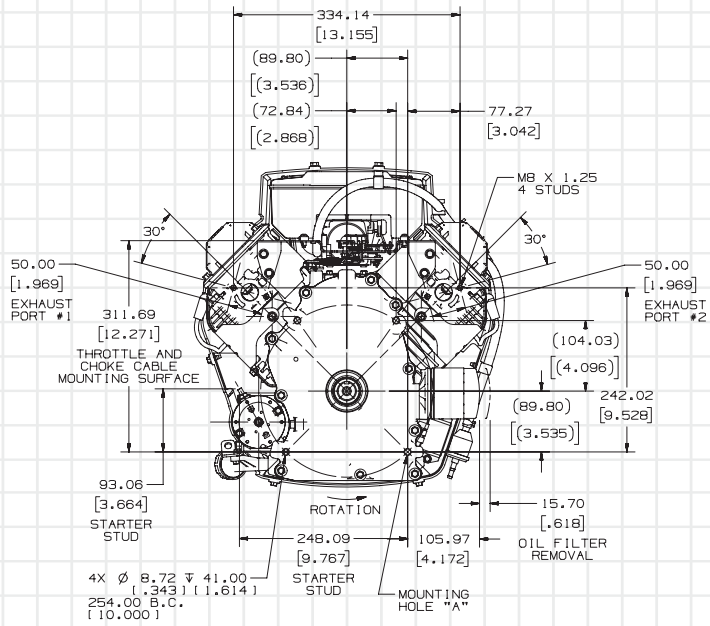

Maximum Torque

Commercial-tough. Consumer-friendly.



Emissions:

Certified for both EPA and California emissions standards. Precise air-to-fuel ratio for cleaner combustion with optimum horsepower and torque.

Service:

Backed by more than 13,000 dealers and distributors worldwide.

Warranty:

Two-year limited warranty covering all consumer applications.

KOHLER® Courage PRO™ V-Twins

With their tough, commercial-duty, high-performance features, they're the Courage® engines gone PRO. And what a perfect time as consumers are demanding more from their equipment and seeking professional-grade performance on their full-featured high-end riders and ZTRs.



Induction- Hardened Crankshaft Bearings.

Bearings are specially heat-treated in order to improve wear behavior and increase durability under high-load, heavy-debris cutting conditions.



Large-Capacity Professional Filters.

For longer life and better performance under tougher conditions. Serious, professional duty – 60 percent larger air and oil filters, 70 percent larger fuel filter.



Platinum Spark Plugs.

For hotter, more reliable sparks; quicker starts; and less plug fouling.



20, 23, 25 and 27 hp vertical-shaft engines

KOHLER® COURAGE PRO® ENGINE ARCHITECTURE

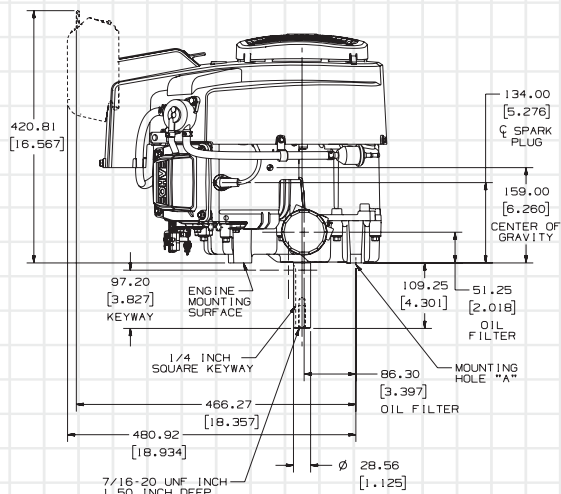
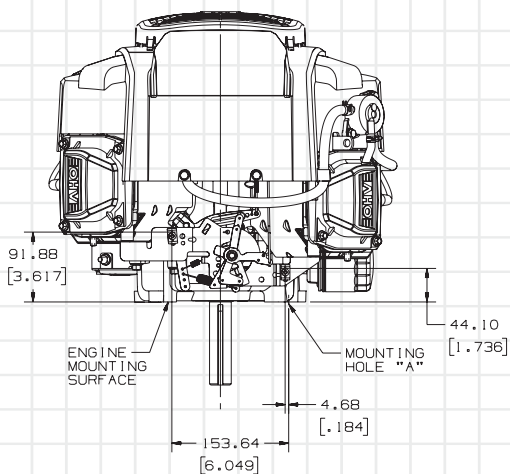
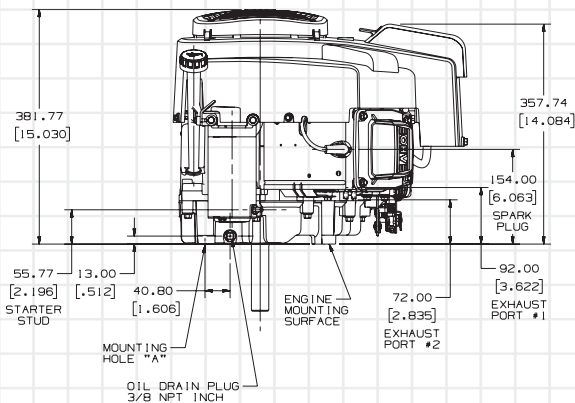

All engine views shown with optional stationary guard.

20, 23, 25 and 27 hp vertical-shaft engines

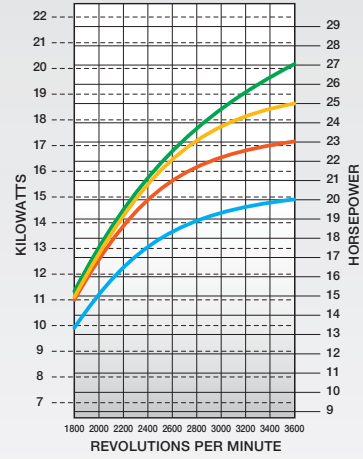
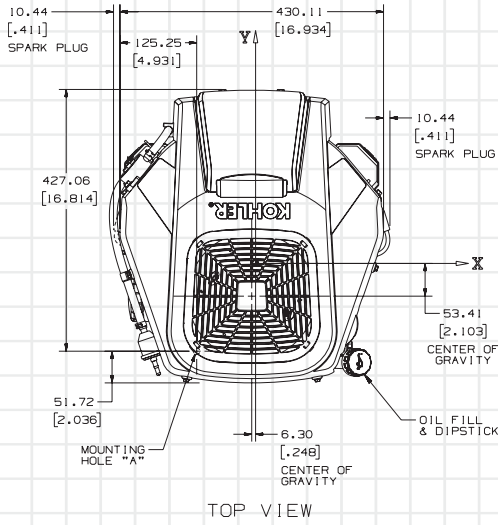

Maximum Power*

- SV840
- SV830
- SV820
- SV810

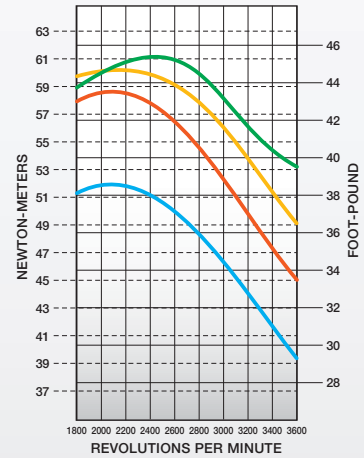
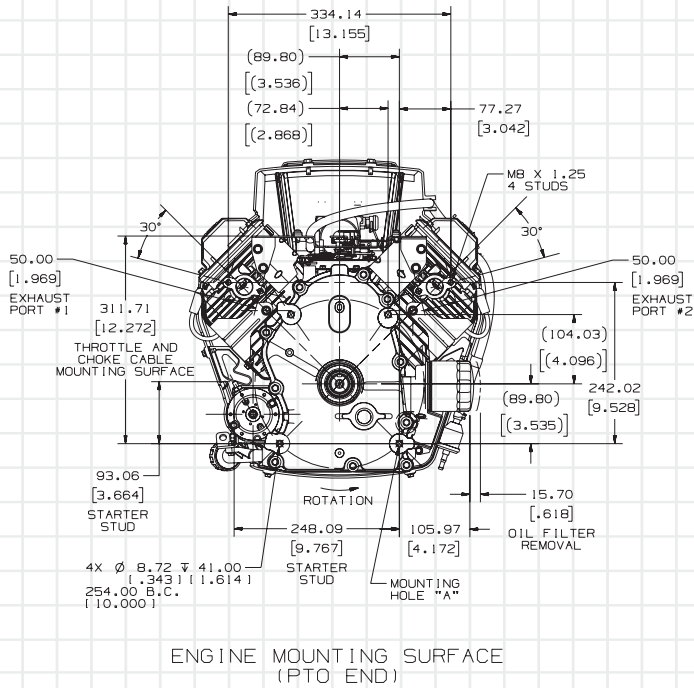

Maximum Torque*

*Preliminary

TOP VIEW

PTO VIEW

More features. More performance. More courage.

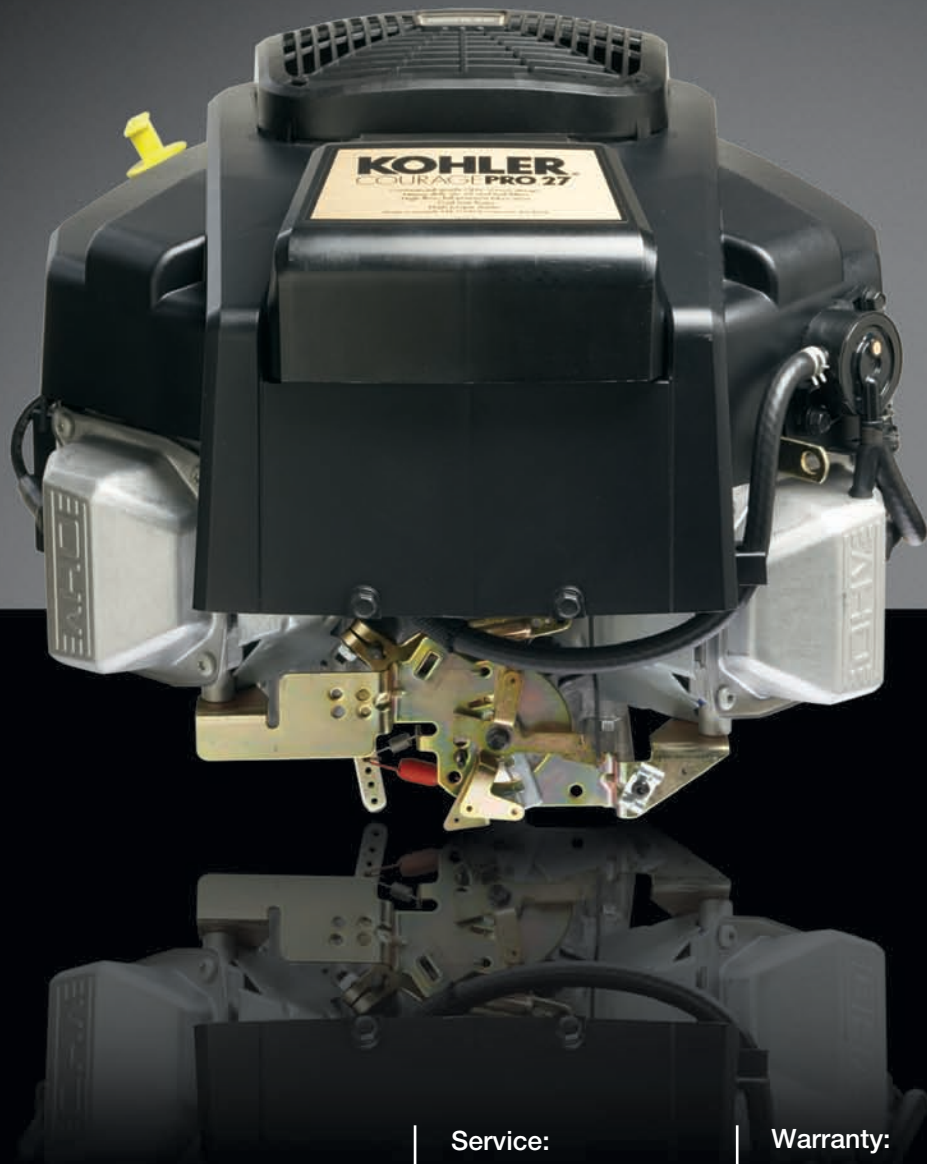

Emissions:

Certified for both EPA and California emissions standards. Precise air-to-fuel ratio for cleaner combustion with optimum horsepower and torque.

Service:

Backed by more than 13,000 dealers and distributors worldwide.

Warranty:

One-year limited warranty covering all commercial applications.

KOHLER® Courage Single-Cylinder Model Specifications

Engine Type		Four-cycle, single-cylinder, air-cooled, vertical-shaft, gasoline, aluminum head and crankcase with cast-iron cylinder liner.							
Model		SV470	SV480	SV530	SV540	SV590	SV600	SV610	SV620
*Power @ 3600 rpm	Maximum hp (kW)	15 (11.2)	16 (11.9)	17 (12.7)	18 (13.4)	19 (14.2)	20 (14.9)	21 (15.7)	22 (16.4)
Displacement	cu in (cc)	36.4 (597)							
Bore	in (mm)	3.7 (94)							
Stroke	in (mm)	3.4 (86)							
Peak Torque @ Maximum rpm	ft lb (Nm)	27 (36.6) @ 2200 rpm	27.9 (37.8) @ 2200 rpm	31.5 (42.7) @ 2200 rpm	32.1 (43.5) @ 2200 rpm	36 (48.8) @ 2200 rpm	36.9 (50) @ 2200 rpm	38.1 (51.6) @ 2200 rpm	38.8 (52.6) @ 2200 rpm
Compression Ratio		8.5:1							
Dry Weight	lb (kg)	79 (35.8)							
Oil Capacity w/Filters	U.S. qt (L)	1.6 (1.5)							
Lubrication		Full-pressure lubrication with full-flow filter							
**Dimensions L x W x H	in (mm)	19.4 x 16.4 x 12.9 (493 x 417 x 328)							

KOHLER Courage® Twin/Courage PRO™ V-Twin Model Specifications

Engine Type		Four-cycle, twin-cylinder, air-cooled, vertical-shaft, gasoline, aluminum head and crankcase with cast-iron cylinder liner.						
Model		SV710/ SV810	SV715	SV720/ SV820	SV725	SV730/ SV830	SV735	SV740/ SV840
*Power @ 3600 rpm	Maximum hp (kW)	20 (14.9)	22 (16.4)	23 (17.2)	24 (17.9)	25 (18.6)	26 (19.4)	27 (20.1)
Displacement	cu in (cc)	44 (725)						
Bore	in (mm)	3.3 (83)						
Stroke	in (mm)	2.6 (67)						
Peak Torque @ Maximum rpm	ft lb (Nm)	38.4 (52) @ 2200 rpm	41.0 (55.6) @ 2200 rpm	43.5 (59) @ 2200 rpm	43.8 (59.5) @ 2200 rpm	44.8 (60.7) @ 2200 rpm	44.4 (60.2) @ 2400 rpm	45.4 (61.5) @ 2400 rpm
Compression Ratio		9:1						
Dry Weight	lb (kg)	91 (41.3)						
Oil Capacity w/Filters	U.S. qt (L)	2 (1.9)						
Lubrication		Full-pressure lubrication with full-flow filter						
***Dimensions L x W x H	in (mm)	Courage 18.5 x 17.8 x 13.4 (471 x 451 x 340)						
		Courage PRO 18.5 x 17.8 x 14.1 (471 x 451 x 358)						

Preliminary information, subject to change.

*Horsepower ratings exceed Society of Automotive Engineers Small Engine Test Code J1940. Actual engine horsepower is lower and affected by, but not limited to, accessories (air cleaner, exhaust, charging, cooling, fuel pump, etc.), application, engine speed and ambient operating conditions (temperature, humidity and altitude). For more information, contact Kohler Co. Engine Engineering.

Kohler reserves the right to change product specifications, designs and equipment without notice and without incurring obligation.

**Length is valve cover to end of blower housing. Width is air cleaner to opposite side. Height is mounting surface to grass screen.

***Length is front of air cleaner cover to end of blower housing. Width is side to side. Height is mounting surface to grass screen.

♻️ 10% total recovered fiber/all post-consumer fiber

For more information, contact your KOHLER source of supply, or call toll-free in the U.S. and Canada 800-544-2444.

Kohler Co., Kohler, Wisconsin 53044 Tel 920-457-4441 Fax 920-459-1570

KohlerEngines.com

© 2010 by Kohler Co. All rights reserved.

KOHLER®, Courage®, Courage PRO™ and Consistent-Cut™ are trademarks of Kohler Co.

KOHLER®

Relentless Power.
Legendary Performance.

Printed in U.S.A. E2122-C 10/10