

Trailed Twin-Disc Fertilizer Spreader

AXENT 100.1



www.kuhn.com



be strong, be **KUHN**



**AXENT**

100.1

SPREADING PRECISION ON A LARGE SCALE!

The new trailed AXENT 100.1 completes the KUHN range of fertilizer spreaders. With its 9,400l hopper with exceptionally high maximum payloads, it has been developed for the biggest cash crop farms as well as contractors.

YOU WANT HIGH YIELDS AT LOW COSTS...

Controlling your application rate helps you maximize crop yield while minimizing your expenses. AXENT 100.1 is the first trailed fertilizer spreader on the market fitted with the EMC system, which continuously adjusts the application rate on each disc separately during spreading. With it you can be sure that the required nutrients are spread on each side at all times.

ABSOLUTE SPREADING PRECISION...

Besides EMC, more unique and proven KUHN solutions provide the spreading precision you expect: CDA distribution system, ISOBUS, GPS control with section control system Varispread and headland management Opti-Point, border spreading to the left and/or right side, pre-metering of AXIS PowerPack before spreading...

AND A SPREADER FOR MOST DIFFERENT PRODUCTS

Other than conventional large-area spreaders, which are designed to spread either granulated or prilled fertilizer, AXENT 100.1 is able to dose and distribute both due to two different spreading modules, which can be quickly interchanged.

The AXENT trailed fertilizer spreader in brief:

Model	Working width (m)	Max. capacity (l)	Products spread
AXENT 100.1 - AXIS PowerPack	18 - 50	9,400	granular fertilizer
AXENT 100.1 - LIME PowerPack	up to 18	9,400	lime, moist bulk, organic fertilizer



PATENT

EMC: PRECISE “WEIGHING” ON EACH DISC!

EMC or „Electronic Mass Flow Control“ is a unique technology, well-established and recognized after years of experience. It measures and continuously adjusts the application rate on each disc separately. The result: 100% of the fertilizer dose spread on each side!



NO METERING COMPROMISES

EMC utilizes the fact that the fertilizer flow rate is proportional to the spreading disc drive torque. This is independent of the type of fertilizer. The intelligent system carries out following steps:

1. Sensors read the torque at each disc.
2. The flow rate is adjusted automatically when deviating from desired value, separately for each disc.
3. Electrically controlled metering outlets are corrected automatically according to new data.

This means that you only have to insert the application rate (kg/ha) and simply start spreading. The system takes care of the rest.

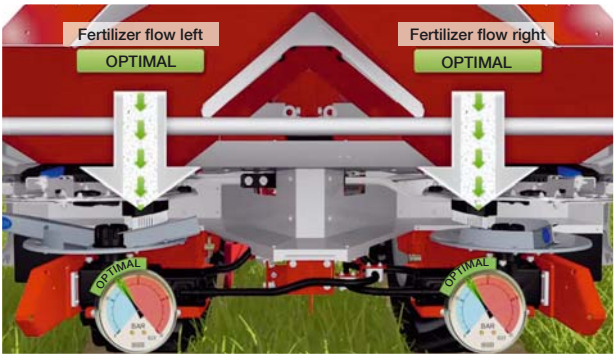

THE EMC ADVANTAGES

- Individual adjustment of left and right disc every second;
- Insensitive to slopes and vibrations;
- More fuel efficiency because of reduced engine speed;
- No increase of machine height or weight;
- No flow test required;
- Impressive flow rate range between 20 and 500 kg/min.

EMC SYSTEM CAN MAKE YOU WIN MORE THAN 1,000€*!

Conventional weighing systems per load cells handle flow faults by acting on the simultaneous opening of the two outlets. At the end of the plot, the average dose spread will be accurate. But when taking a closer look, it turns out that the “live” application rate is inaccurate. The EMC independent regulation on each disc is a unique solution to solve this issue.

**Estimation calculated based on 25% blockage with a 9,400l hopper capacity for the second 33.5% calcium ammonium nitrate supply to a soft wheat cultivation.*

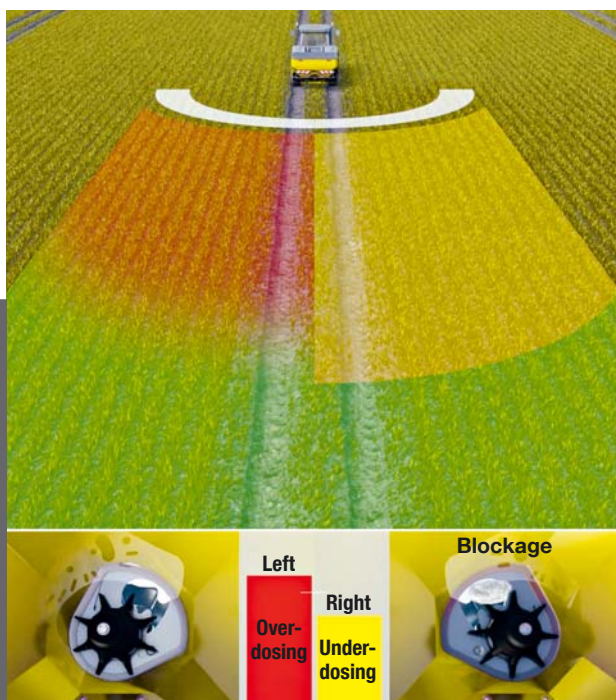

CLASSIC WEIGHING SYSTEM (W)

As the flow rate is adjusted every second by spreaders with weighing systems, deviations from the previously set application rate are quickly corrected in general.

If one outlet is blocked, the weighing spreader opens both metering outlets until the foreign body can fall through. In this moment, the application rates on both sides are over-dosed.

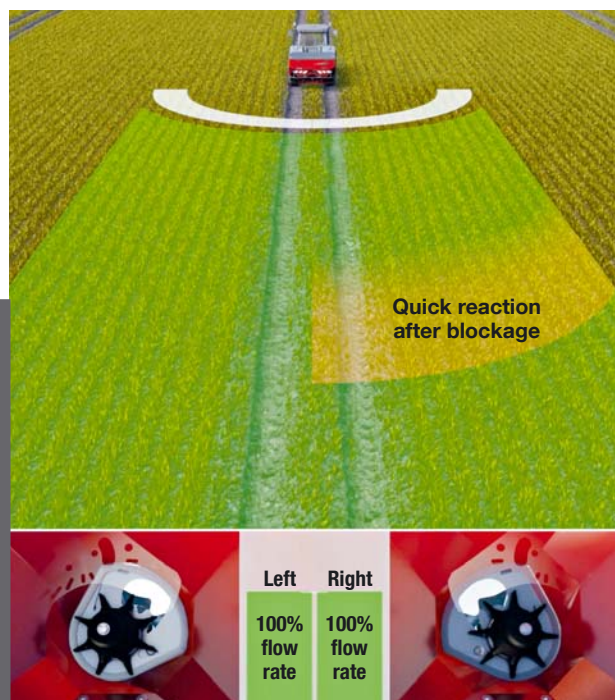

“WEIGHING” DISC BY DISC (EMC)

After opening the metering outlets, EMC spreaders directly record the actual flow rate on each side every second. This way, they work with high precision already from the first metres on.

In the case of clogging of one metering outlet, the EMC system reacts instantaneously. The foreign object is quickly removed by opening the concerned outlet completely, while the other side is not affected at all.

CONSEQUENTLY THE EMC INDEPENDENT REGULATION FOR EACH DISCS HELPS YOU:

- to avoid wasting fertilizer, which won't be absorbed by plants,
- to save up to 1,000€ per AXENT hopper load.



Eric Gage from Saaten Union Research station in the French Oise region is convinced by the EMC system:

“As we need the spreading to be perfectly homogeneous, weighing on each disc is important. When taking into account the surface and kilos spread, it is perfect. On each test carried out, we were always below 1% error with regards to the set application rate.”

TWO MACHINES IN ONE

Typical large area fertilizer spreaders are either not capable of spreading lime or to do so greatly reduces fertilizer spread patterns and working widths. Up to now contractors needed to invest in two different machines to achieve high spreading accuracy for all products, although both spreaders are used at different times in the season.



ONE SPREADER. TWO SPREADING MODULES.

There is now an alternative. AXENT 100.1 is the first modular high-capacity fertilizer spreader on the market spreading both types of product with the expected precision. The solution is surprisingly simple: With AXENT you have one spreader with two different spreading modules, which can be interchanged via a quick-change system, making it a high-tech solution for large cash crop farms as well as contractors.



LIME POWERPACK FOR SOIL-ENRICHING AGENTS

With its 700 mm diameter heavy discs, this spreading table is designed to spread heavy and wet products: lime, moist bulk, organic fertilizer (pellets)...at high application rates of several tons per hectare over a maximum width of 18m. The conveyor belt is used exclusively to meter the material according to groundspeed (DPAE) and the selected rate. A hydraulically driven agitator improves flow to the spreading discs.

Note: EMC, VARISPREAD Dynamic and OPTIPOINT are only compatible with the AXIS PowerPack, not with the Lime PowerPack.

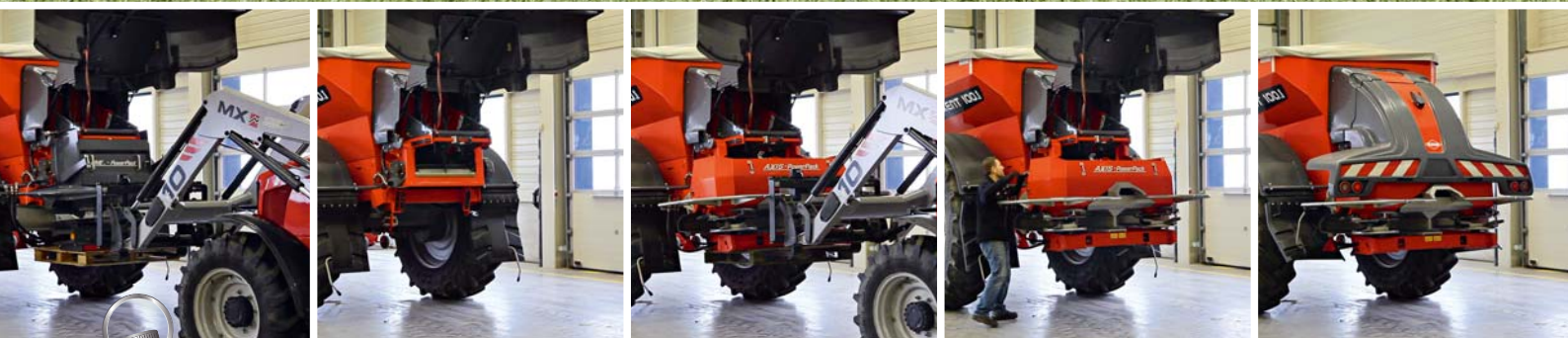

MODULES ARE INTERCHANGED IN ONLY 10 MINUTES!

A clever and comfortable fast-fit system makes it possible to switch from one configuration to the other in only ten minutes. This can be handled by only one person.



AXIS POWERPACK FOR GRANULAR FERTILIZER

The AXIS PowerPack is the hydraulically driven spreading module for high-precision spreading of granulated fertilizer. Based on the well-proven AXIS H-EMC model design, the fertilizer system allows granulated fertilizer and seeds to be spread with ultimate precision from 18 to 50m. The AXIS PowerPack includes all the advantages of a mounted AXIS spreader to ensure high precision spreading. Apart from EMC, this includes ISOBUS, automatic section control with VARISPREAD Dynamic, precise headland management with OPTIPOINT variable rate application, CDA distribution, a flow rate of up to 500kg/min, an ultra-slow rotating agitator as well as remote-controlled border spreading on both sides.

AXIS PRECISION FEATURES PACKED INTO AXENT



VARISPREAD DYNAMIC: DON'T THINK IN SECTIONS ANYMORE!

As standard, AXENT is capable of section control for reducing fertilizer use and over application. The special VARISPREAD Dynamic system is unique on the market. In manual mode, four section per side are selectable. In automatic GPS mode, the system adjusts the drop point and disc speed constantly, resulting in a continuously variable spread width. This allows for better overlap control in odd-shaped and wedged fields.

VARIABLE RATE APPLICATION (VRA)

Via the CCI.Control app you can directly upload application maps in standardized formats on your CCI terminal in order to apply variable rates, which respond to differing field and crop conditions. The application is guided via GPS. You can also connect and display VRA maps on many terminals from other manufacturers. In this way, the application maps and machine functions can also be displayed separately on the two screens.

PRECISE UP TO THE FIELD BORDER

Border spreading is accomplished on the AXENT fertilizer spreader by reducing disc speed and/or modifying the drop point to avoid the fertilizer being spread beyond the border. It can be engaged on either the left- or right-hand side via the control terminal.



THE KUHN PLUS

PRECISION FULLY AUTOMATED

Special feature on AXIS PowerPack: The endless conveyor rubber belt (8mm thick) fills a pre-chamber above the spreading discs, providing totally automated fertilizer supply. No driver intervention is required. As soon as the fertilizer level gets low, the feeding belt will automatically start up again. The EMC system then controls the left and right metering slide at the base of the pre-chamber. Certainly also fully automated!

HIGH-TECH FOR YOUR BENEFIT



PRESERVE YOUR PLANTS DURING LATE TOP DRESSING

The AXENT spreader can be equipped with an optional steering axle for smoother headland turn manoeuvres, limiting crop flattening and improving the machine's performance on slopes. The Trail Control system uses a small gyroscope positioned on the tractor to adjust the machine's wheel angle on the headland. The steering angle ranges between 10 to 17 degrees depending on track width and tyre size selected. A fast and simple solution, when the spreader is used on several tractors!

OPTIMIZE YOUR LOGISTICS

For precise documentation and improved operator comfort, four integrated weighing cells, available on option, allow you to always monitor the total remaining fertilizer load and area left to spread before reloading becomes necessary.

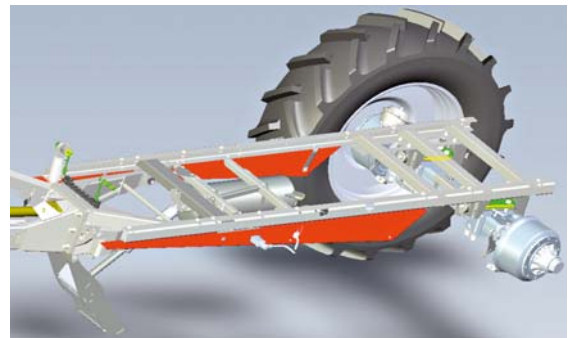

USE YOUR TRACTOR ISOBUS TERMINAL FOR PRECISION FARMING FUNCTIONS

The AXENT is equipped as standard with ISOBUS technology and is compatible with different ISOBUS terminals, from KUHNS CCI 200 to Müller Comfort and John Deere GS 2630 terminal.

Compatible functions: section control, variable rate application, application rate adjustments, machine adjustments, fast emptying.



PREMIUM FEATURES BUILT INTO EVERY MACHINE



EQUIPPED ALSO FOR SMALLER TRACTORS

No oil flow is needed from the tractor, as the AXENT spreader has its own hydraulic system on board as standard. This hydraulic unit is PTO powered with a Vario system (from 700 to 1,000 min⁻¹), which reduces the tractor's fuel consumption. It drives the spreading discs, conveyor belt, metering outlets, the agitator on the Lime PowerPack as well as the steering axle. That's why tractors from 180hp can pull an AXENT.



HYDRAULIC COMFORT FEATURES AS STANDARD

KUHN has paid extra attention to a high operator's comfort. In this context following features are part of the standard AXENT package:

- linkage drawbar with hydro-pneumatic suspension to provide extra comfort on roads and in the field.
- hydraulic hopper cover for considerable faster loading,
- integrated hydraulic parking stand controlled from the cab allows for faster and simpler coupling/uncoupling operations.



CAMERA MAKES REVERSING SAFER

The backup camera, which is integrated into the rear cover, allows for safer manoeuvring into barns and sheds.



INTERNAL TESTING. CREATING EXPERT KNOW-HOW.

Many spreading tests have been carried out in our internal test hall to this day. It helps us create spreading charts, increase setting precision and finding new technological solution for your benefit.



be strong, be **KUHN**

KUHN PARTS

Designed and manufactured to rival time



KUHN foundries and forge as well as a high-level manufacturing process allow the production of spare parts to defy time. You can truly rely on our know-how and our genuine parts. Farmers benefit from our client support and logistics services via any KUHN PARTS warehouse, which provide quick and reliable repair solutions in cooperation with your nearest authorized KUHN dealer.



Technical specifications

	AXENT 100.1
Maximum hopper capacity (l)	9,400
Spreading modules	AXIS PowerPack: for fertilizer granules OR Lime PowerPack: for lime, moist bulk, organic fertilizer
Working width (m/ft)	AXIS PowerPack: 18 - 50 / 59' - 164' (depending on fertilizer) Lime PowerPack: up to 18 / 59' (depending on product)
Maximum payload (kg/lbs)	7,400 / 16,315 - 8,400 / 18,520 - 10,400 / 22,930*
Weight empty without spreading table (kg/lbs)	4,250 / 9,370
Weight approx. of spreading table (kg/lbs)	350 / 770 (both AXIS and Lime PowerPack)
Total weight (kg/lbs)	12,000 / 26,455 - 13,000 / 28,660 - 15,000 / 33,070*
Filling height (m/ft)	2.90 / 9'6"
Transport height (m/ft)	3.15 / 10'4"
Overall width (m/ft)	2.55 / 8'4" (with 2.00m track)
Overall length without spreading module (m/ft)	7.70 / 25'3"
Track widths (m/ft)	2.00/6'7" - 2.10/6'11" - 2.15/7'1" - 2.25/7'5"
Axle	rigid or steering (with gyroscope)
Brake system	hydraulic or pneumatic**
ISOBUS	◆
Control terminal	CCI or any other ISOBUS-compatible terminal
Electronic groundspeed related application rate control (DPAE)	◆
VARISPREAD section control	AXIS PowerPack: dynamic as standard (by modifying disc speed, drop point and reducing the application rate) Lime PowerPack: simultaneous opening/closing of the 2 outlets
OPTIPOINT headland management	◆
Border spreading	AXIS PowerPack: to left and/or right by reducing the drive speed and modifying the drop point
Fertilizer low level sensor	◆
Rear camera	◆
Hopper cover	◆ (with hydraulic control)
Hopper base	conveyor rubber belt: 8mm thick, 800mm wide
Foldable ladder	◆ (in front of the hopper)
Min. power requirement (kW/hp)	135 / 180
Integrated hydraulic unit	◆ (for drive of belt, metering outlets, spreading discs)
Tractor hydraulic requirements	2x DA (parking stand, hopper cover)
Lighting and signalling	rear LED lighting + signalling panel

◆ standard equipment ◇ optional equipment - not available

*Depending on drawbar type and country. Please always check with your local dealer.

**Some configurations are not available in all countries. Please always check with your local dealer.

Optional equipment: AXIS PowerPack or Lime PowerPack - steering axle – four weighing cells – hydraulic or pneumatic brakes** - different tyre options according to track width (520/85 r42 ac 85 wheel 2.00m, 520/85 r46 ac 85 wheel 2.10m, 520/85 r42 ac 85 wheel 2.25m).

KUHN SERVICES* Maximize the use and productivity of your KUHN equipment

*Not all services and equipment are available in every country.

KUHN sos order

EXPRESS SPARE PARTS SERVICE 24/7

You urgently need spare parts? With KUHN sos order benefit from express delivery seven days a week, 365 days a year. Thus, you can minimize machine downtime considerably and increase your work output.

KUHN protect +

THE CHOICE OF PROFESSIONALS!

Benefit from 36 months in complete serenity because of KUHN's protect+ warranty. You can concentrate exclusively on your work and the performance of your machine. Because this is what you expect, when investing in high-tech machinery.

KUHN i tech

FOR EVER QUICKER REPAIRS!

An unexpected technical problem always occurs at the wrong time. Your KUHN dealer can support you quickly and efficiently thanks to KUHN i tech. With this 24/7 online service, a quick and exact diagnosis is possible.

KUHN finance

INVEST RATIONALLY!

New machine necessary, financing unsure? Modernize your equipment and develop your farm with KUHN finance, in total safety and according to your needs and demands. We offer custom-made finance solutions, adapted to your requirements.

SMALL PROGRAMS WITH GREAT IMPACT!

SPREADER ADJUSTMENT MADE EASY

For increased fertilizer spreading efficiency, KUHN provides the SPREADSET application to assist you in adjusting your fertilizer spreader. The app integrates all spreading charts available from KUHN. After having selected the fertilizer type as well as other parameters such as the spreading width or type of disc, SPREADSET guides you through the right settings to apply in order to spread the right dose and obtain a good crosswise fertilizer distribution.



Available on App Store and Google Play.



Twin disc fertilizer spreaders



Pneumatic fertilizer spreaders



Lifting equipment

For more information about your nearest KUHN dealer, visit our website www.kuhn.com



Visit us on our YouTube channels.

 www.kuhn.com	Your KUHN dealer
---	------------------

KUHN S.A.

4 Impasse des Fabriques - BP 50060
F-67706 Saverne CEDEX - FRANCE

KUHN NORTH AMERICA, INC.

1501 West Seventh Avenue - Brodhead,
WI 53520 - USA

KUHN FARM MACHINERY PTY. LTD

313-325 Foleys Road - Deer Park, VIC, 3023 - AUSTRALIA

KUHN FARM MACHINERY (U.K.) LTD

Stafford Park 7 - GB TELFORD/ SHROPS TF3 3BQ

Information given in this document is only for information purposes and is non-contractual. Our machines are in compliance with regulations in force in the country of delivery. In our literature, and for improved illustration of certain details, some safety devices may not be in operating position. When operating these machines, these devices must be in position in accordance with the requirements indicated in the operator's manuals and assembly manuals. Respect the tractor gross vehicle weight rating, its lift capacity and maximum load per axle and tyres. The tractor front axle load must always comply with the regulations of the country of delivery (In Europe, it must reach minimum 20 % of the tractor net weight). We reserve the right to change any designs, specifications or materials listed without further notice. Machines and equipment in this document can be covered by at least one patent and/or registered design. Trademarks cited in this document may be registered in one or several countries.

Also find KUHN on

